



8903/CN ControlNet Communications Interface

Technical Manual

HA469263U001 Issue 2

Compatible with 890 Firmware Version 1.4 onwards

© Copyright 2005 SSD Drives Limited (formerly Eurotherm Drives Limited)

All rights strictly reserved. No part of this document may be stored in a retrieval system, or transmitted in any form or by any means to persons not employed by an SSD Drives company without written permission from SSD Drives Ltd.

Although every effort has been taken to ensure the accuracy of this document it may be necessary, without notice, to make amendments or correct omissions. SSD Drives cannot accept responsibility for damage, injury, or expenses resulting therefrom.

Safety Information



WARNING!

During commissioning, remove the fuses (or trip the circuit breaker) on your 3-phase supply.
Make sure the power is OFF, and that it cannot be switched on accidentally whilst you are working.

Please read this information **BEFORE** installing the equipment.

Intended Users

This manual is to be made available to all persons who are required to install, configure or service equipment described herein, or any other associated operation.

The information given is intended to highlight safety issues, and to enable the user to obtain maximum benefit from the equipment.

Application Area

The equipment described is intended for industrial motor speed control.

Personnel

Installation, operation and maintenance of the equipment should be carried out by qualified personnel. A qualified person is someone who is technically competent and familiar with all safety information and established safety practices; with the installation process, operation and maintenance of this equipment; and with all the hazards involved.

REFER TO YOUR MAIN PRODUCT MANUAL FOR SPECIFIC SAFETY INFORMATION ABOUT THE DEVICE YOU ARE CONTROLLING

Acknowledgements

DSE (Drives System Explorer) is a registered trademark of SSD Drives, Inc.

RSLogix 5000 and RSNetworx for ControlNet are registered trademarks of Allen-Bradley, Inc.

ControlNet is a trademark of ControlNet International, Ltd.

WARRANTY

SSD Drives warrants the goods against defects in design, materials and workmanship for the period of 12 months from the date of delivery on the terms detailed in SSD Drives Standard Conditions of Sale IA058393C.

SSD Drives reserves the right to change the content and product specification without notice.

Contents

Contents

Page

CONTROLNET COMMUNICATIONS INTERFACE	1
Introduction	1
Product Features	1
Product Code.....	1
Installation	2
Wiring the System	5
Channel LED Indications	6
Initial Power-on Checks	6
Drive Diagnostics	6
• The ControlNet MMI View	6
• Parameter Descriptions	7
Configuring the ControlNet System	8
Step 1: Configuring the ControlNet TechCard using DSE 890	8
• Step 1.1: Inserting a CONTROLNET Function Block.....	8
• Step 1.2: Attaching Fieldbus Connectors	8
• Step 1.3 : Configuring the Fieldbus Connectors.....	9
• DSE Data Types	11
• ControlNet PLC Data Types.....	11
• Conversion of DSE Type < > ControlNet PLC Type	11
• ControlNet Status Information	12
Step 2: Configuring the PLC using RSLogix 5000	13
Step 3: Configuring the ControlNet Network using RSNetwork for ControlNet	17
Example ControlNet Configuration	18
Appendix A : Troubleshooting	22
• 890 ControlNet TechCard Status LEDs.....	22
Appendix B : DSE/ControlNet Conversion Rules	23
• LOGIC Type Connector	23
• INTEGER Type Connector.....	24
• VALUE Type Connector	25

CONTROLNET COMMUNICATIONS INTERFACE

Introduction

This manual describes the SSD Drives' ControlNet™ Communications Interface Option (TechCard).

Product Features

- Available for 890 products
- Easy plug-in installation
- Suitable for use with drive models:
 - 890CD Common Bus Drive and 890SD Standalone Drive
 - using 890 firmware version 1.4 onwards
- Channel A and Channel B coaxial ports and NAP port (non-isolated)
- LED's to indicate board and communications status
- Hardware/software selectable Node Address

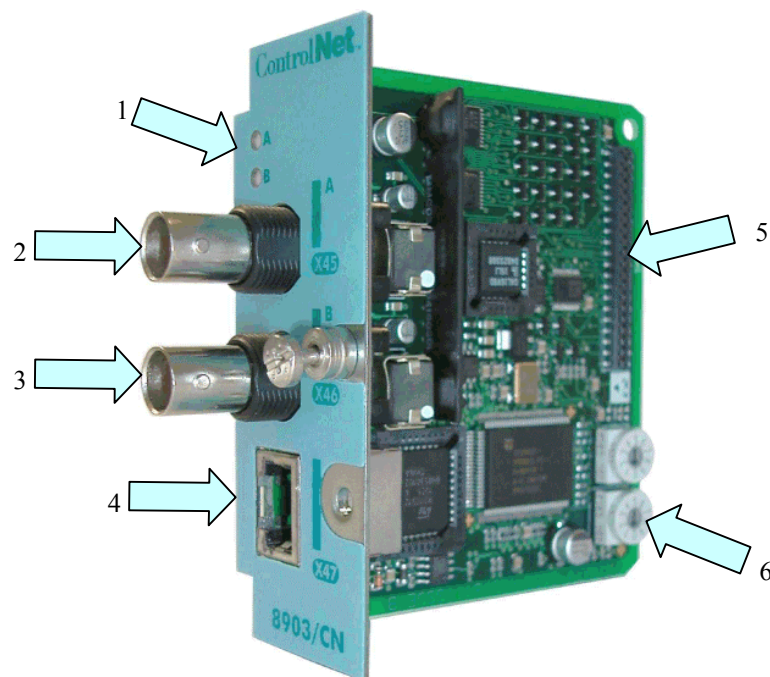

1	LEDs for Channel A and Channel B	4	X47 - NAP port (Network Access Port)
2	X45 - Channel A	5	Connector to Control Board
3	X46 - Channel B	6	Node Address Switches

Figure 1. ControlNet TechCard

Product Code

Part Number: 8903/CN/00 - ControlNet TechCard

2

Installation

WARNING!

Before installing, ensure that the drive wiring is electrically isolated and cannot be made "live" unintentionally by other personnel.
Wait 5 minutes after disconnecting power before working on any part of the system or removing the covers from the drives.

To Remove the Control Board

1. Remove the blank covers, each secured by a single screw, that fit over the TechCard holes.
2. Loosen the top and bottom screws in the blue handles of the Control Board (2).
3. Pull gently on the handles and slide the Control Board (2) out of the drive.

Note: Save the blank cover and screw for future use. The drive should not be operated without a TechCard or blank cover. When fitted, these maintain the drive's IP20 rating.

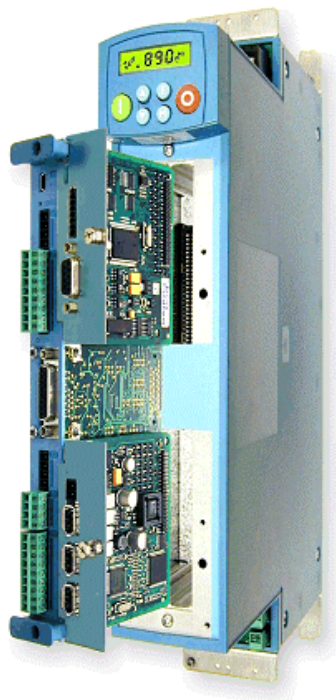

Figure 2. 890 showing Control Board withdrawn with Options fitted

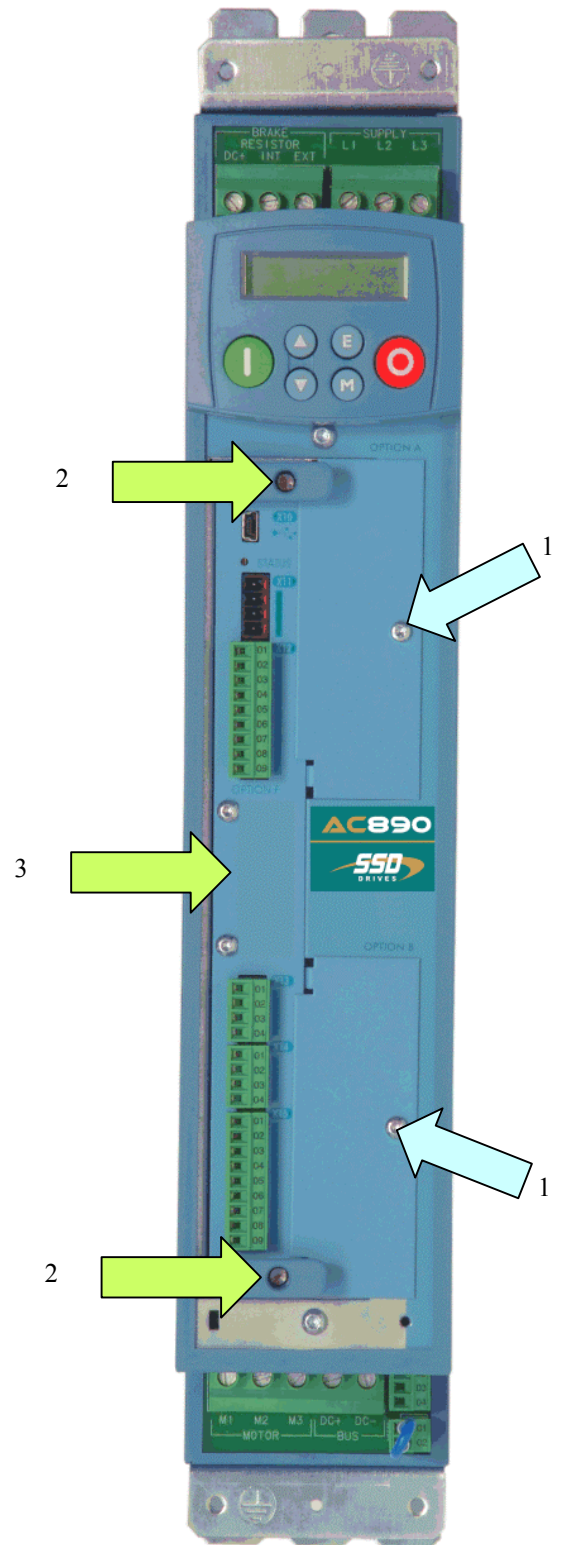

Figure 3. Front of 890 drive showing Control Board fitted

Setting the Node Address

The 890CD and 890SD drives are configured identically.

The Node Address is set via the Node Address Switches on the TechCard. Set a value of between 1 and 99 before installation.

Alternatively, setting both switches to zero allows the Node Address to be set using the DSE 890 Configuration Tool via the CONTROL NET::NODE ADDRESS parameter.

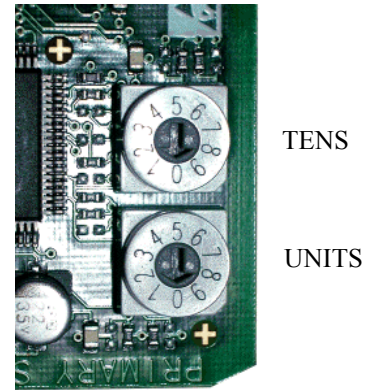

Figure 4. Node Address Switches

Fitting the TechCard

The TechCard fits onto the Control Board.

1. Insert the connector into the TechCard as shown. The legs of the connector will protrude through into the connector on the other side of the TechCard.
2. Press the assembly into the **TOP** connector (adjacent to terminals X10, X11 and X12) on the Control Board. Ensure that the front panel of the TechCard overlaps the front of the Control Board. Ease the connector at the TechCard so that the two pcb's are parallel when viewed on edge.

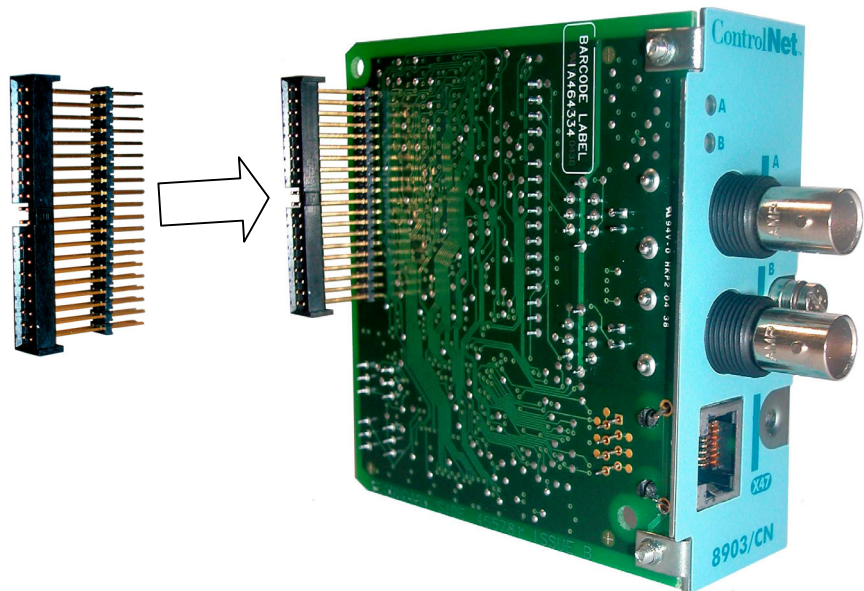

Figure 5. Fitting the connector to the TechCard

Re-fitting the Control Board

1. Slide the board into the drive, engaging the edges of the boards into the slots. Push until the back edge of the Control Board pcb locates with the connectors in the drive.
2. Tighten in position using the top and bottom screws in the blue handles of the Control Board.
3. Screw the TechCard in position using the captive screw on the front of the TechCard.

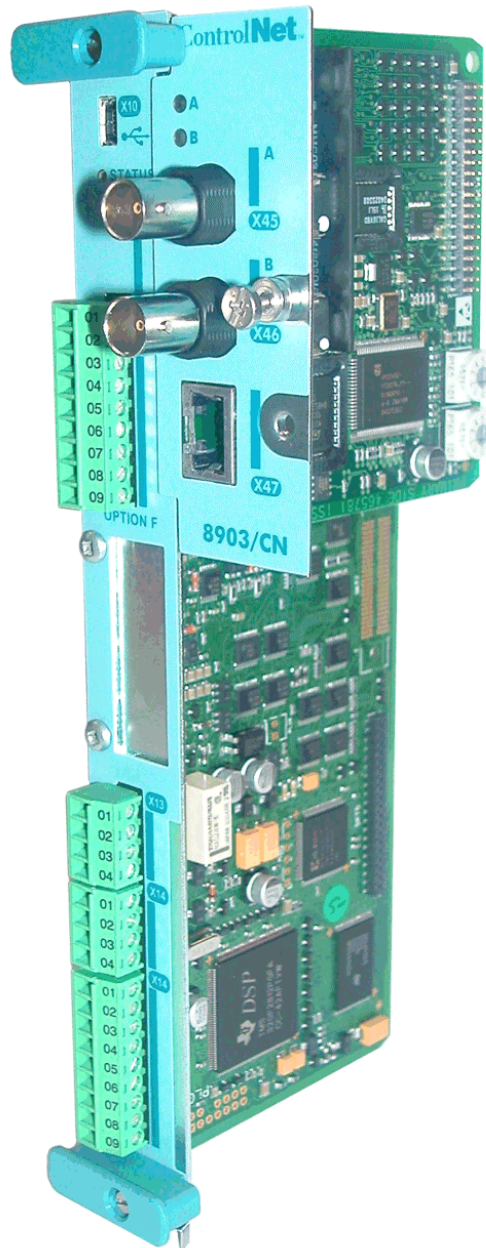

Figure 6. 890 Control Board with TechCard fitted

Wiring the System

Cable Specifications

The recommended trunk cable section is quad shield RG-6 type co-axial cable.

Use taps to connect to the TechCards. A 75Ω terminator must be installed on the end taps.

The network uses either Channel A, Channel B, or both. The diagram below shows a customer PLC ControlNet card connected to two TechCards (nodes) using Channels A and B. When both terminals are in use, the TechCard uses the terminal offering the better quality signal.

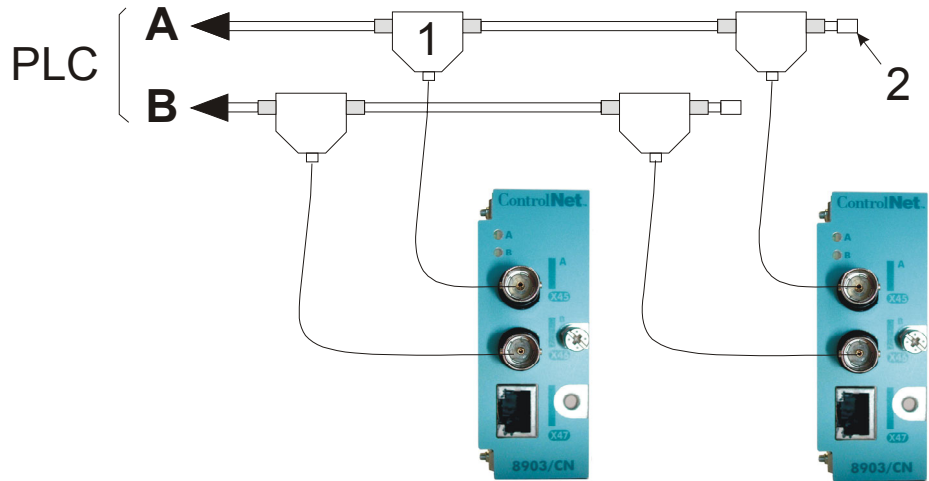

1	Tap	2	Terminator
---	-----	---	------------

Figure 7. Simple Wiring Diagram

Note: For more information about cabling and terminators, refer to www.ControlNet.org.

6

Channel LED Indications

LEDs A & B indicate the state of the connected network.

A = Channel A, B = Channel B.

Initial Power-on Checks

With the correct connections to the active PLC/SCADA supervisor, LED's A and/or B will display as shown below.

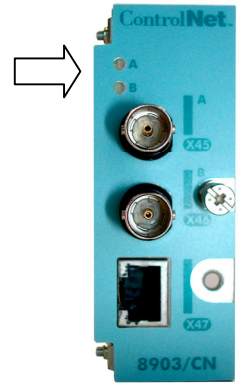



Colour	LED Indication	Description
 GREEN	A or B : ON	NORMAL OPERATION OF CHANNEL
 GREEN	A or B : FLASH	NO NODE ADDRESS SET

Figure 8. Channel LED Indication

Note: Refer to Appendix A : Troubleshooting, page 22 for details of other indications.

Drive Diagnostics

The ControlNet MMI View

With the ControlNet TechCard correctly installed, the MMI will display a new set of parameters for CONTRONET.

These are read-only parameters - diagnostics.

MMI Menu Map

- 1 SETUP
- 2 COMMUNICATIONS
- 3 CONTROLNET
 - NODE ADDRESS
 - ADDRESS METHOD
 - NETWORK MODE
 - CONNECTED
 - CNET STATE
 - SERIAL NUMBER
 - FAULT
 - DIAGNOSTIC

Parameter Descriptions

NODE ADDRESS	<i>Read Only</i>	<i>Range: 1 to 99, and 0</i>
Displays the ControlNet node address of the drive the card is fitted to (displayed as MAC Id in DSE 890).		
ADDRESS METHOD	<i>Read Only</i>	<i>Range: Enumerated - see below</i>
Diagnostic showing the node address method. If either of the Node Address switches on the ControlNet TechCard are set to non-zero value at power-up, then the method is HARDWARE , otherwise it is SOFTWARE .		
<i>Enumerated Value : Address Method</i>		
0 : HARDWARE		
1 : SOFTWARE		
NETWORK MODE	<i>Read Only</i>	<i>Range: Enumerated - see below</i>
State of the ControlNet network connection.		
<i>Enumerated Value : NETWORK MODE</i>		
0 : INVALID		
1 : POWER UP		
2 : CHECK FOR CABLE		
3 : WAITING TO ROGUE		
4 : CHK 4 MODERATOR		
5 : I'M ALIVE		
6 : ATTACHED		
7 : FORCED LISTEN		
8 : DUPLICATE NODE		
CONNECTED	<i>Read Only</i>	<i>Range: FALSE / TRUE</i>
If TRUE indicates that a Class 1 connection is open.		
CNET STATE	<i>Read Only</i>	<i>Range: Enumerated - see below</i>
State of ControlNet application.		
<i>Enumerated Value : CNET STATE</i>		
0 : NONE board not attached		
1 : FAULT		
2 : INITIALISE		
3 : VM CONFIGURE waiting for a valid CNet configuration		
4 : WAIT 2 ATTACH		
5 : WAIT 2 CONNECT		
6 : RUNNING		
SERIAL NUMBER	<i>Read Only</i>	<i>Range: decimal value</i>
Unique serial number of TechCard.		
FAULT	<i>Read Only</i>	<i>Range: FALSE / TRUE</i>
If TRUE , indicates a ControlNet fault.		
DIAGNOSTIC	<i>Read Only</i>	<i>Range: 0x0000 to 0xFFFF</i>
ControlNet diagnostic value. "0000" = No Fault.		
Contact SSD Drives for assistance if any other value appears.		

Configuring the ControlNet System

To configure the ControlNet system, complete the steps below. Our example is shown using a PLC running RSLogix 5000. For other systems, refer to the manufacturer's instructions.

Step 1: Configuring the ControlNet TechCard using DSE 890

You can configure your ControlNet TechCard using DSE 890.

Follow the instructions below.

Step 1.1: Inserting a CONTROLNET Function Block

Display your configuration page. Click on the Block menu at the top of the screen.

1. Move the cursor down to select "890 Comms" and select "ControlNet".
2. Click to attach the block icon to the cursor. Move the icon to where you want on the screen. Click again to release the icon.

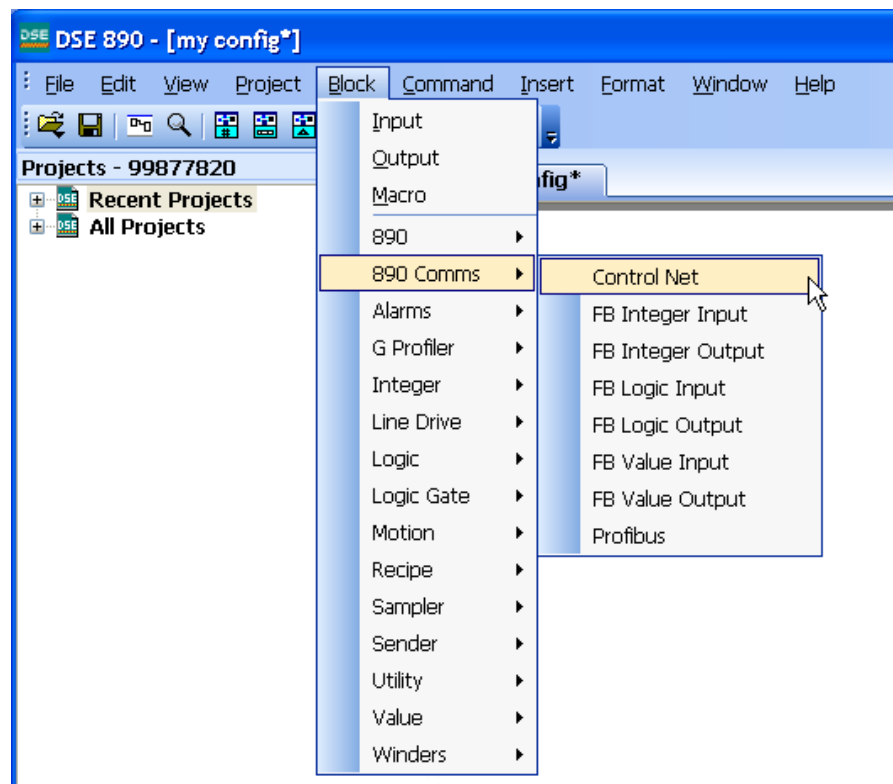

Figure 17. Configuration showing CNET function block and Fieldbus Connectors

Step 1.2: Attaching Fieldbus Connectors

Six fieldbus connector types are available:

FB Logic Input

FB Integer Input

FB Value Input

FB Logic Output

FB Integer Output

FB Value Output

Input connector : the data is sent from PLC → 890

Output connector : the data is sent from 890 → PLC

The fieldbus connectors must be added before they will appear in the ControlNet function block.

Note: The function block and connectors can be renamed by using the right mouse button and selecting **Rename Block**.

Step 1.3 : Configuring the Fieldbus Connectors

Double-click on the function block to display the dialog below. The fieldbus connectors (inputs and outputs) are assignable in the function block along with their data type to/from the PLC. The option slot and MAC Id can also be selected.

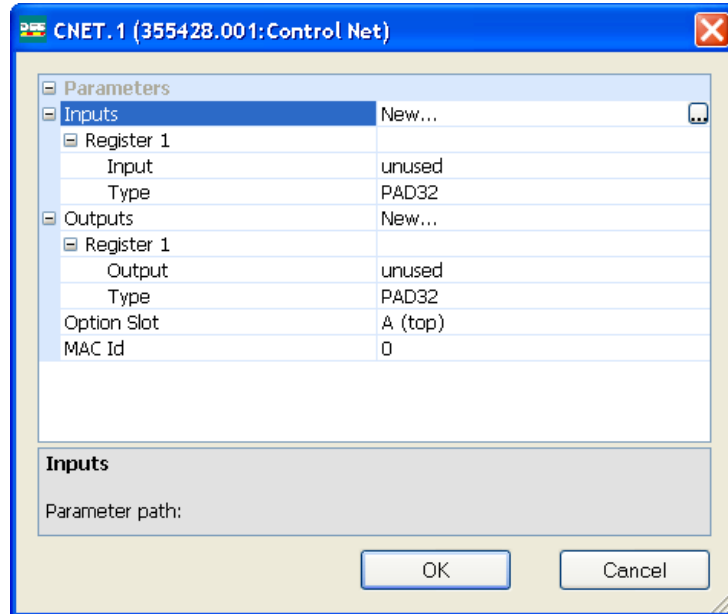

To configure the input and output connectors you have placed in the configuration:

1. Expand the **Inputs** and **Outputs** trees to reveal the registers. By default the trees each have one register. To add more registers click on  adjacent to **New...**

Note: Note that once a register has been added it cannot be deleted. However, by setting it to "unused", and setting its Type to "NONE", it will be disregarded by the 890 DSE tool.

2. Select the drop-down menu adjacent to **Input** to choose the required input/output connector on the Register. For example below, Register 1 "Input" is shown with the possible fieldbus selections that have been placed in the configuration: FII.1 (Fieldbus Integer Input 1), FLI.1 (Fieldbus Logic Input 1), FVI.1 (Fieldbus Value Input 1) etc.

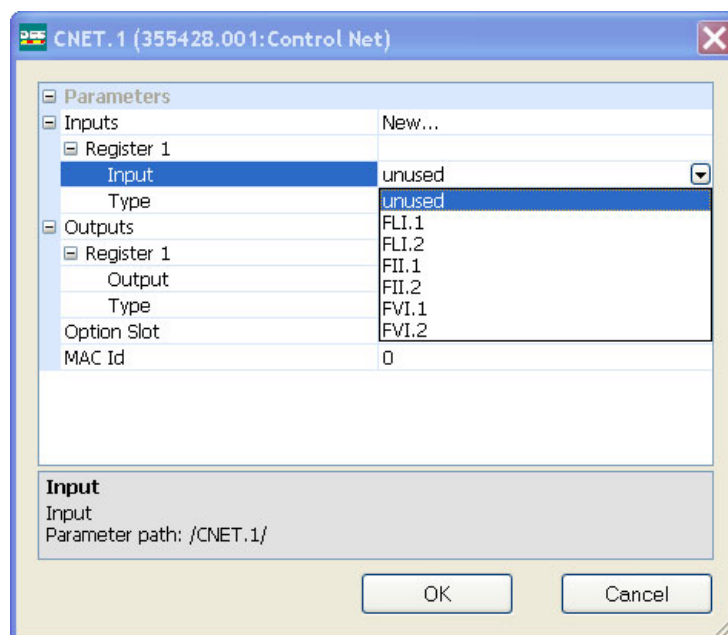

3. Select the drop down menu adjacent to **Type** to choose the required PLC type on Register 1, for example.

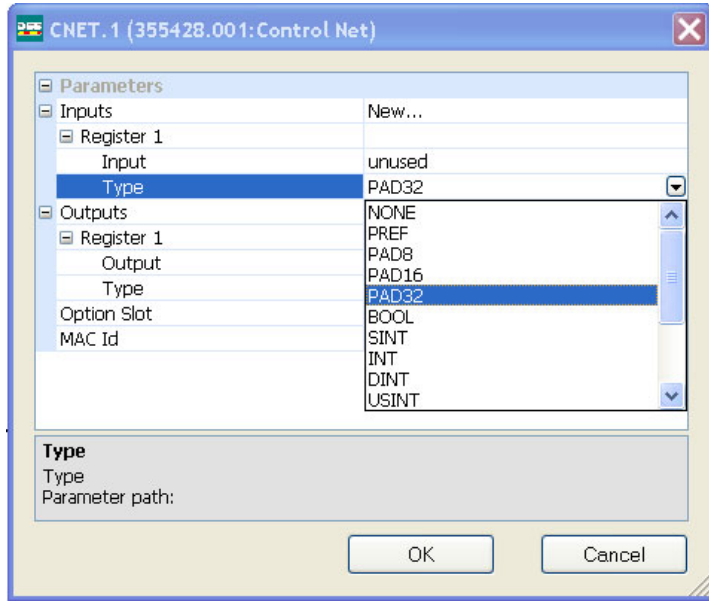

The three padding types PAD8, PAD16 and PAD32 can be used to align data in the PLC configuration. When using padding, the register should be set to "unused" so that no fieldbus connector is associated with it.

4. Set up all the input/output registers in a similar way.

Remember:

- ◆ The order of the *inputs* in the DSE ControlNet configuration MUST match the order of the *outputs* from the PLC configuration.
- ◆ The order of the *outputs* in the DSE ControlNet configuration MUST match the order of the *inputs* to the PLC configuration.
- ◆ In the PLC configuration, the first four bytes of the input data are reserved.

5. The MAC Id can be selected in the range 1 – 99. This can be confirmed by the NODE ADDRESS diagnostic on the Keypad.

Note: The MAC Id set in DSE 890 will only be used if the Node Address switches on the ControlNet TechCard are set to zero, otherwise the switch address on the TechCard will take precedence.

6. "Option Slot" = A (top). The ControlNet TechCard can only be fitted in the OPTION A slot on the front of the drive. This is the default setting for "Option Slot".

MMI Menu Map

- 1 SETUP
- 2 COMMUNICATIONS
- 3 CONTROLNET
 - | NODE ADDRESS
 - | ADDRESS METHOD
 - | NETWORK MODE
 - | CONNECTED
 - | CNET STATE
 - | SERIAL NUMBER
 - | FAULT
 - | DIAGNOSTIC

DSE Data Types

Data Type	Description	Range
LOGIC	Logic	False (F) and True (T)
INTEGER	32-bit signed integer	-2,147,483,648 to 2,147,483,647
VALUE	32-bit fixed point value	-32768.0 to 32767.9999

ControlNet PLC Data Types

Data Type	Description	Range	Bytes Used
BOOL	8-bit Boolean	False (0x00) and True (0x01)	1
SINT	8-bit signed integer	-128 to 127	1
INT	16-bit signed integer	-32,768 to 32,767	2
DINT	32-bit signed integer	-2,147,438,648 to 2,147,483,647	4
USINT	8-bit unsigned integer	0 to 255	1
UINT	16-bit unsigned integer	0 to 65,535	2
UDINT	32-bit unsigned integer	0 to 4,294,967,295	4
BYTE	8-bit bit-string	0x00 to 0xFF	1
WORD	16-bit bit-string	0x0000 to 0xFFFF	2
DWORD	32-bit bit-string	0x0000 0000 to 0xFFFF FFFF	4
REAL	32-bit IEEE-754 floating-point value	1.19209290e-38 to 3.4028235e+38	4
PAD8	8-bit pad	-	1
PAD16	16-bit pad	-	2
PAD32	32-bit pad	-	4
PREF	Reserved	-	-

Conversion of DSE Type < > ControlNet PLC Type

The DSE fieldbus connectors are each assigned a ControlNet PLC "Type" as described in "Step 1.3 : Configuring the Fieldbus Connectors" on page 9.

The conversion between the DSE type and the PLC type is performed automatically.

Any PLC type can be assigned to a fieldbus connector, although some are not supported (refer to Appendix B : DSE/ControlNet Conversion Rules, page 23).

Some recommended PLC type assignments to fieldbus connectors are given in the table below:

Application Data Type	Fieldbus Connector	PLC Type	Bytes Allocated
Boolean	LOGIC	BOOL	1
32-bit signed integer	INTEGER	DINT	4
32-bit floating-point	VALUE	REAL	4
8-bit bit-string	INTEGER	BYTE	1
16-bit bit-string	INTEGER	WORD	2
32-bit bit-string	INTEGER	DWORD	4

ControlNet Status Information

The ControlNet function block in DSE 890 shows the selected MAC Id. When online, the *actual* MAC Id in use can be found by clicking the right mouse button over the “MAC Id:” text and selecting **Get**. This may be different to the MAC Id set in the function block configuration if the MAC Id has been set by the rotary switches on the TechCard.

The function block also provides two status outputs that can be wired to: NET MODE and CONNECTED.

For example, the CONNECTED output could be ANDed with the motor START causing the drive to stop if the PLC connection is lost.

Note: *A PLC connection is possible regardless of the PLC mode.*

The NET MODE output could be used with the LOGIC::LOOKUP function block to determine a particular state.

NET MODE

Enumerated values:	Network Mode State
	0: INVALID
	1: POWER UP
	2: CHECK FOR CABLE
	3: WAITING TO ROGUE
	4: CHECK FOR MODERATOR
	5: I'M ALIVE
	6: ATTACHED
	7: FORCED LISTEN ONLY
	8: DUPLICATE NODE

CONNECTED

Logic value:	True (T) indicates a Class 1 connection is open
--------------	---

Step 2: Configuring the PLC using RSLogix 5000

This section contains an example for configuring a PLC using RSLogix 5000.

1. Start a new program and select the PLC processor and chassis type that is used in your project. Our example uses a 1756-L55 processor and 1756-A7 chassis. Remain Offline until you are ready to download the program.
2. In the I/O configuration, select the ControlNet scanner. Right click on the I/O Configuration folder to select a New Module. Select the type of scanner module that is used in the PLC.

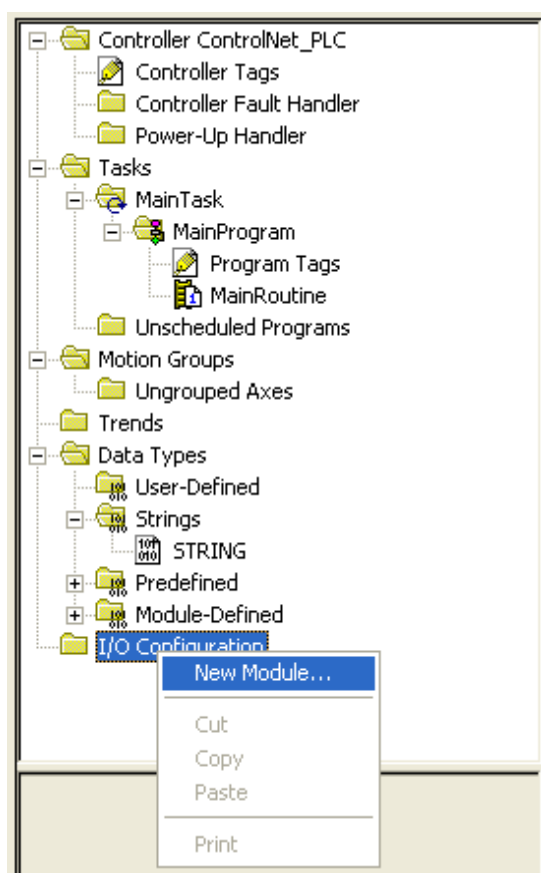

Figure 10. Selecting New Module

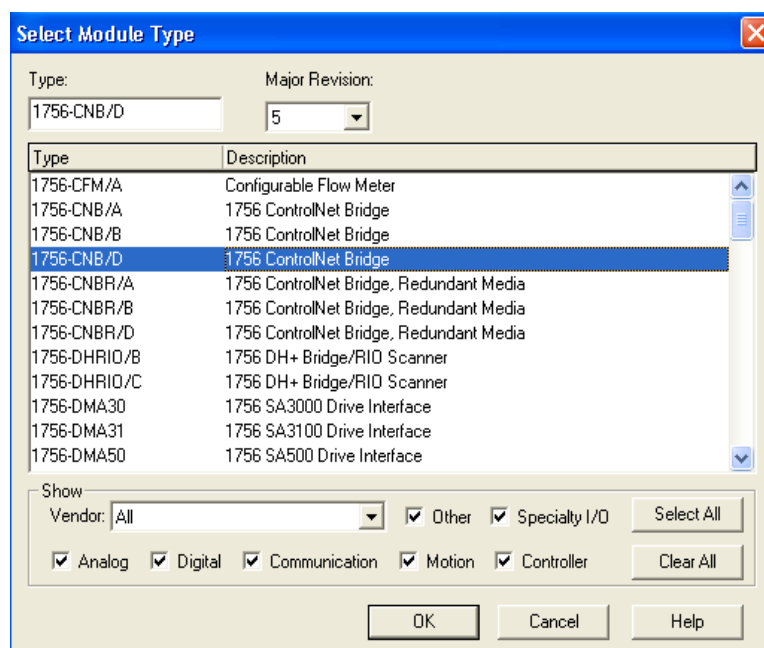

Figure 11. Select Scanner

3. Under the scanner card, add a new module. Right click on the scanner module and select New Module. Select Generic ControlNet module.
4. Module properties window allows you to name the module and to set the network address, data type and data size.
5. The input assembly instance is 2 and the output assembly instance is 1. Set the size as appropriate for your configuration. The configuration instance is 3 and the size is 0. The comms format is set for "DATA-SINT" to allow transfer of 8-bit bytes. Refer to Figure 14.
6. Click the NEXT button to enter the settings for the Requested Packet Interval. The default setting should be sufficient for most applications. When finished with the Requested Packet Interval screen, click the FINISH button to exit. Refer to Figure 15.

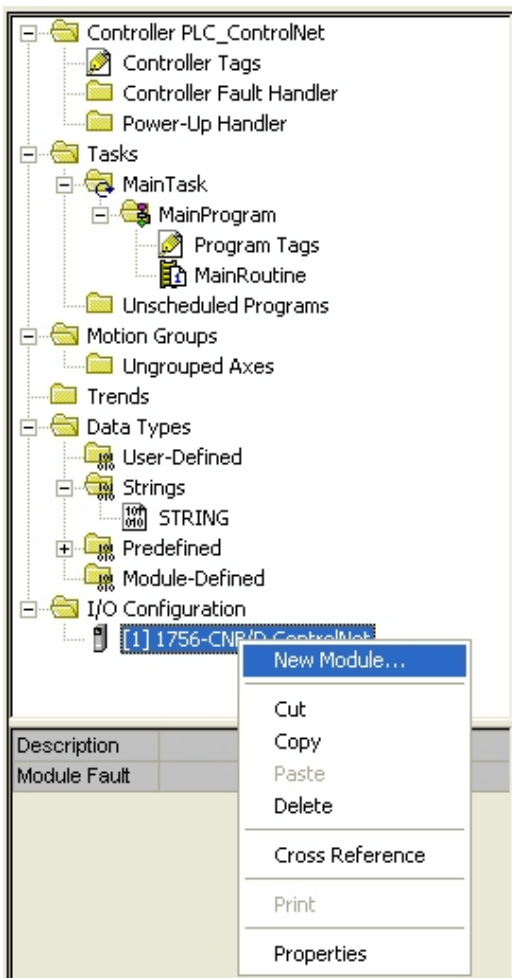

Figure 12. Select New Remote Module

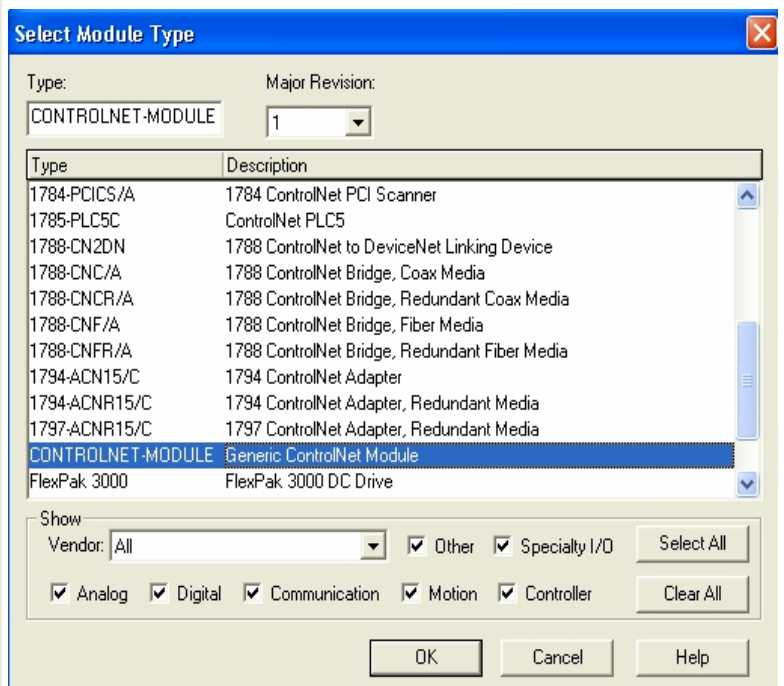

Figure 13 Select Remote Module Type

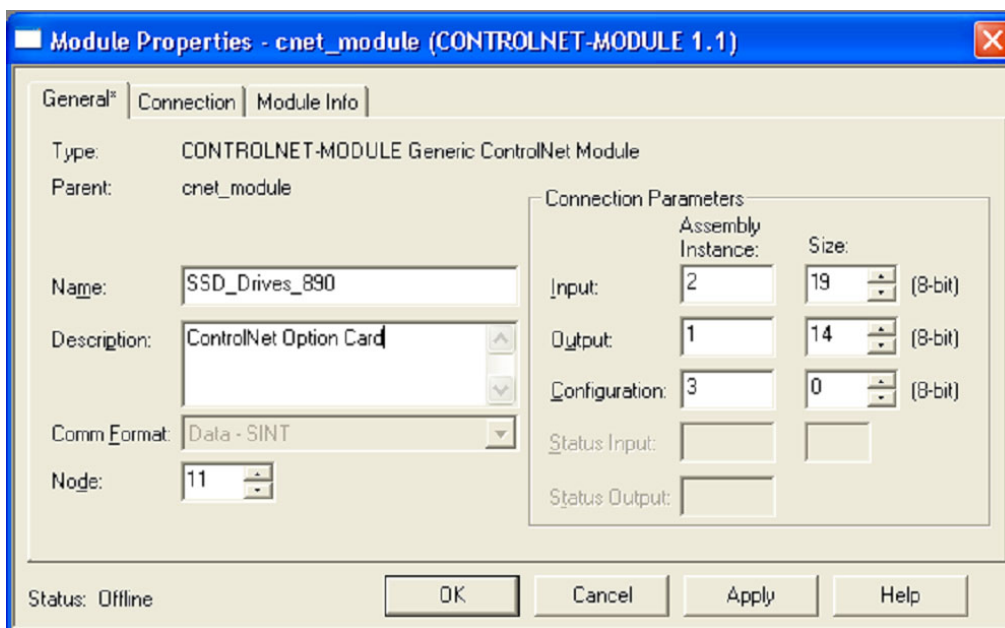

Figure 14. Defining the Module Name and Data Size

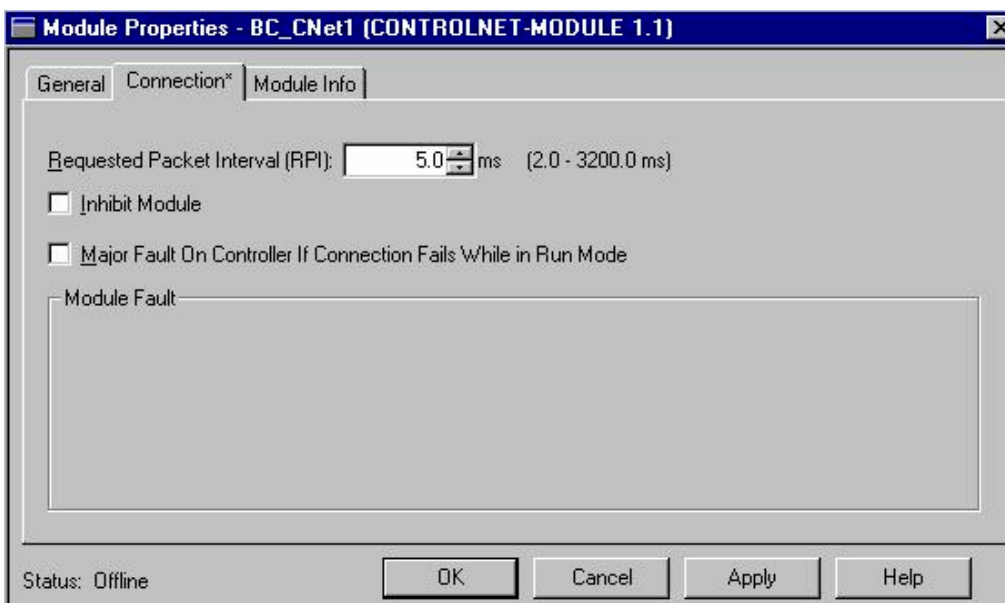

Figure 15. Packet Rate Selection

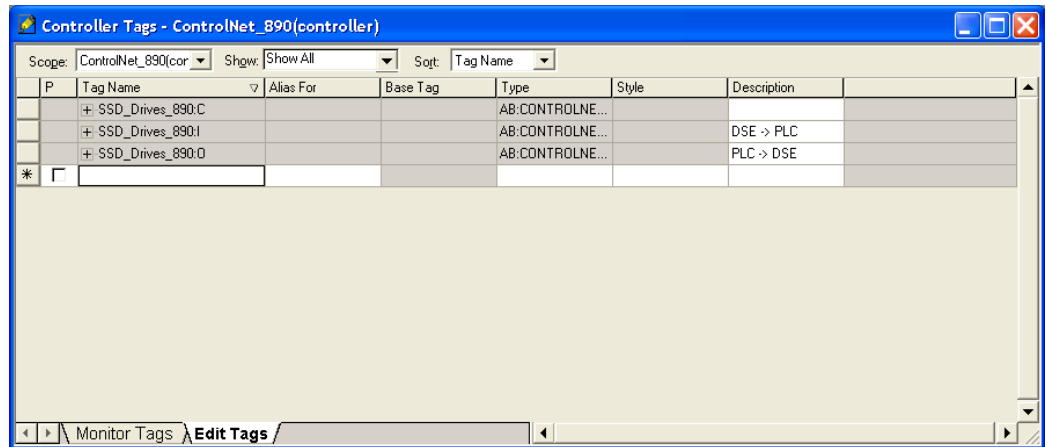

Figure 16. Monitor Tags

7. To monitor the tags created, double-click on Controller Tags. Refer to Figure 16.
8. The PLC automatically creates a configuration data block. The block always ends with a "C". This block is part of every configuration. "SSD_Drives_890:C" was created for this module. The type and size of the data is fixed, (Type: SINT, Size: 400 bytes). This configuration data block is created regardless of the configuration size.
9. The input and output data is configured as 8-bit bytes (SINT). This data needs to be reconstructed to the required format. This can be done by writing a PLC program using copy instructions to produce new tags for each parameter.
10. Once the PLC program is configured for the TechCard, the program can be downloaded to the PLC. The program needs to be loaded in the PLC prior to configuring the ControlNet interface using RSNetworkx. This will ensure proper configuration for the ControlNet network.
11. The PLC should be put in Run Mode for the PLC program to run.
12. As the ControlNet scanner has not yet been configured to communicate an error "Connection not scheduled" will be reported. The connection is scheduled using RSNetworkx for ControlNet.

Step 3: Configuring the ControlNet Network using RSNetworx for ControlNet

The fastest way to configure the ControlNet network is by using RSNetworx for ControlNet, and with all the nodes connected to the network.

1. The EDS file is available on our web site, www.SSDdrives.com. Load the EDS file first. Using the Tools menu, select EDS Wizard. The EDS wizard will guide you through the process.

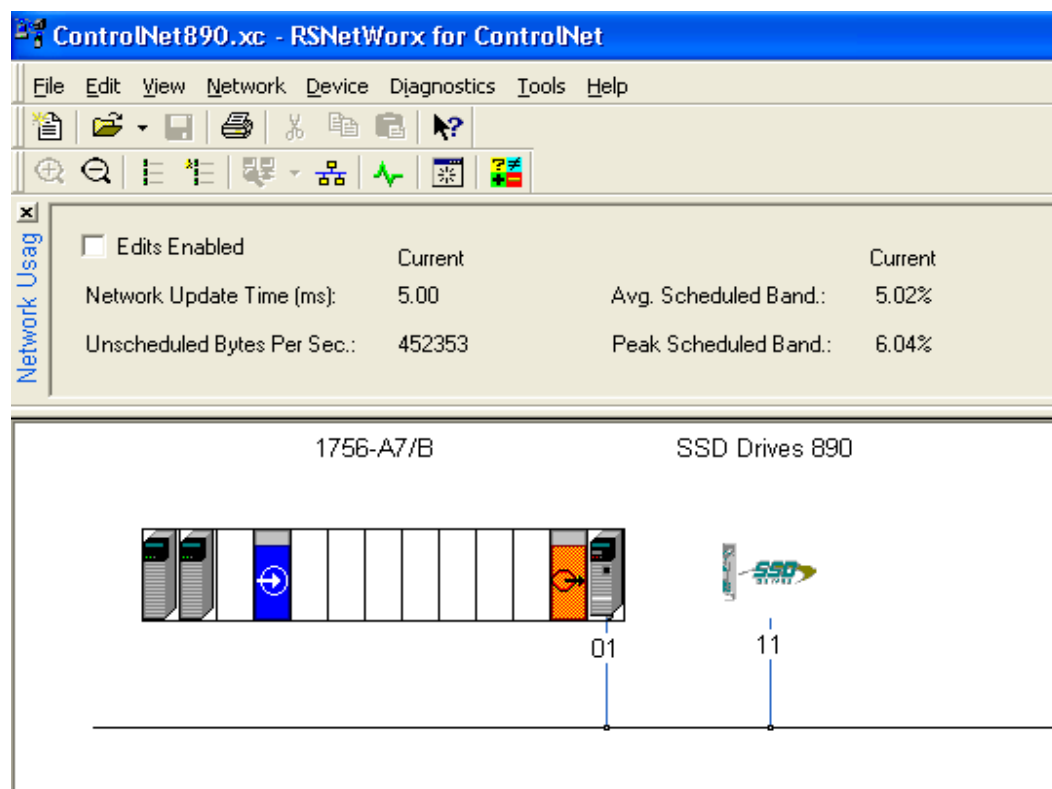

Figure 9 RSNetworx configuration screen

2. Refer to the instruction manual to set the scanner network address.
3. Ensure that all nodes on the network have a valid address set.
4. The RSNetworx software queries the network and reads the PLC configuration to generate the proper network configuration. This is done by selecting **NETWORK → ONLINE**. RSNetworx should see the nodes on the network.
5. RSNetworx is used to configure the network update time. Right click in the area outside of the modules and select Properties. Enter the update time and other network parameters as needed. The Network Update Time must be no less than 5ms and shorter than the PLC Requested Packet Interval. After configuring the rack and setting the network update time, you should have updates pending to the network.
6. To schedule connections and save the configuration to file, check the Edits Enabled box and select **FILE → SAVE**. After the network changes have been saved, the network and the I/O should become healthy.

Example ControlNet Configuration

DSE Configuration

The configuration below uses a MAC Id of 6 and has the following inputs and outputs:

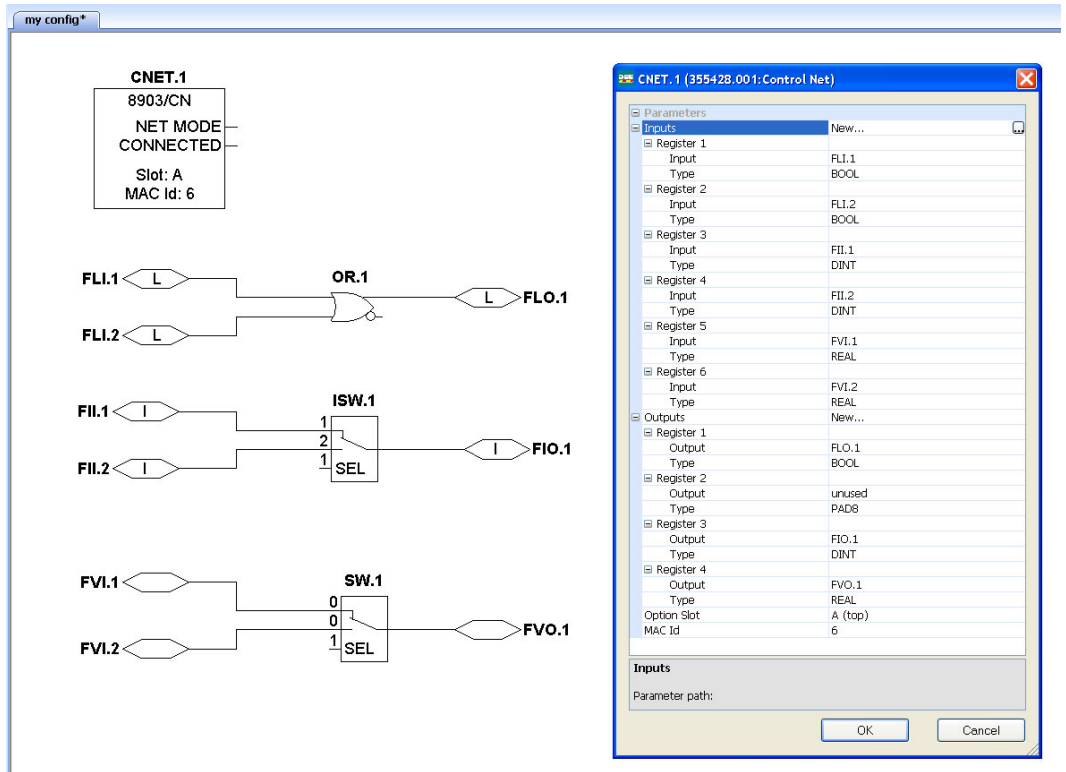

890 Inputs (PLC outputs)				
Register	Connector type	PLC type	PLC offset (bytes)	Bytes allocated
1	LOGIC	BOOL	0	1
2	LOGIC	BOOL	1	1
3	INTEGER	DINT	2	4
4	INTEGER	DINT	6	4
5	VALUE	REAL	10	4
6	VALUE	REAL	14	4
TOTAL				18 bytes

890 Outputs (PLC inputs)				
Register	Connector type	PLC type	PLC offset (bytes)	Bytes allocated
Reserved	-	-	0	4
1	LOGIC	BOOL	4	1
2	unused	PAD8	5	1
3	INTEGER	DINT	6	4
4	VALUE	REAL	10	4
TOTAL				14 bytes

RSLogix 5000 Configuration

To set up the PLC using RSLogix5000, choose the Generic ControlNet Module. An example of setting up the Module Properties is shown below. We recommend to use the Comm Format as **Data – SINT** so that all data is treated as individual 8-bit bytes.

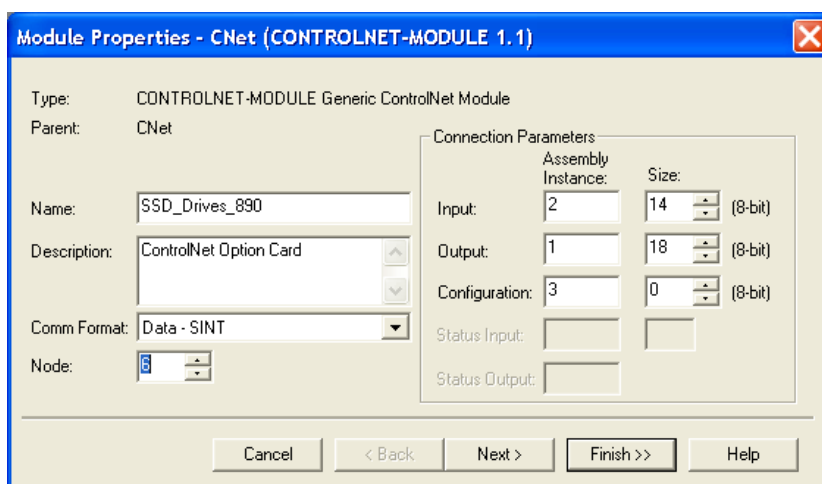

Note: Remember that 890 outputs are PLC inputs, and vice-versa.

This will result in the Controller Tags shown below (the description comments have been added).

The screenshot shows the 'Controller Tags' window for 'ControlNet_890(controller)'. The tags are organized into two main sections: 'SSD_Drives_890:I' (inputs) and 'SSD_Drives_890:O' (outputs). Each section has a 'Data' array and individual bit/byte tags. The 'Data' arrays are of type 'SINT' and 'Decimal'. The individual tags are of type 'SINT' and 'REAL'. The descriptions include comments like 'DSE -> PLC' and 'PLC -> DSE'.

Tag Name	Value	Style	Type	Description
SSD_Drives_890:C	(...)		AB:CONTROLNET_...	
SSD_Drives_890:I	(...)		AB:CONTROLNET_...	DSE -> PLC
SSD_Drives_890:I.Data	(...)	Decimal	SINT[14]	
SSD_Drives_890:I.Data[0]	0	Decimal	SINT	reserved
SSD_Drives_890:I.Data[1]	0	Decimal	SINT	reserved
SSD_Drives_890:I.Data[2]	0	Decimal	SINT	reserved
SSD_Drives_890:I.Data[3]	0	Decimal	SINT	reserved
SSD_Drives_890:I.Data[4]	0	Decimal	SINT	FLO.1 (BOOL)
SSD_Drives_890:I.Data[5]	0	Decimal	SINT	pad
SSD_Drives_890:I.Data[6]	0	Decimal	SINT	FI0.1 (DINT) byte 1 (LSB)
SSD_Drives_890:I.Data[7]	0	Decimal	SINT	FI0.1 (DINT) byte 2
SSD_Drives_890:I.Data[8]	0	Decimal	SINT	FI0.1 (DINT) byte 3
SSD_Drives_890:I.Data[9]	0	Decimal	SINT	FI0.1 (DINT) byte 4 (MSB)
SSD_Drives_890:I.Data[10]	0	Decimal	SINT	FV0.1 (REAL) byte 1 (LSB)
SSD_Drives_890:I.Data[11]	0	Decimal	SINT	FV0.1 (REAL) byte 2
SSD_Drives_890:I.Data[12]	0	Decimal	SINT	FV0.1 (REAL) byte 3
SSD_Drives_890:I.Data[13]	0	Decimal	SINT	FV0.1 (REAL) byte 4 (MSB)
SSD_Drives_890:O	(...)		AB:CONTROLNET_...	PLC -> DSE
SSD_Drives_890:O.Data	(...)	Decimal	SINT[18]	
SSD_Drives_890:O.Data[0]	0	Decimal	SINT	FLI.1 (BOOL)
SSD_Drives_890:O.Data[1]	0	Decimal	SINT	FLI.2 (BOOL)
SSD_Drives_890:O.Data[2]	0	Decimal	SINT	FI1.1 (DINT) byte 1 (LSB)
SSD_Drives_890:O.Data[3]	0	Decimal	SINT	FI1.1 (DINT) byte 2
SSD_Drives_890:O.Data[4]	0	Decimal	SINT	FI1.1 (DINT) byte 3
SSD_Drives_890:O.Data[5]	0	Decimal	SINT	FI1.1 (DINT) byte 4 (MSB)
SSD_Drives_890:O.Data[6]	0	Decimal	SINT	FI1.2 (DINT) byte 1 (LSB)
SSD_Drives_890:O.Data[7]	0	Decimal	SINT	FI1.2 (DINT) byte 2
SSD_Drives_890:O.Data[8]	0	Decimal	SINT	FI1.2 (DINT) byte 3
SSD_Drives_890:O.Data[9]	0	Decimal	SINT	FI1.2 (DINT) byte 4 (MSB)
SSD_Drives_890:O.Data[10]	0	Decimal	SINT	FVI.1 (REAL) byte 1 (LSB)
SSD_Drives_890:O.Data[11]	0	Decimal	SINT	FVI.1 (REAL) byte 2
SSD_Drives_890:O.Data[12]	0	Decimal	SINT	FVI.1 (REAL) byte 3
SSD_Drives_890:O.Data[13]	0	Decimal	SINT	FVI.1 (REAL) byte 4 (MSB)
SSD_Drives_890:O.Data[14]	0	Decimal	SINT	FVI.2 (REAL) byte 1 (LSB)
SSD_Drives_890:O.Data[15]	0	Decimal	SINT	FVI.2 (REAL) byte 2
SSD_Drives_890:O.Data[16]	0	Decimal	SINT	FVI.2 (REAL) byte 3
SSD_Drives_890:O.Data[17]	0	Decimal	SINT	FVI.2 (REAL) byte 4 (MSB)

To reconstruct the data from individual bytes new tags can be created. A ladder program, etc. can be used to copy the data to/from the new tags. An example is shown below.

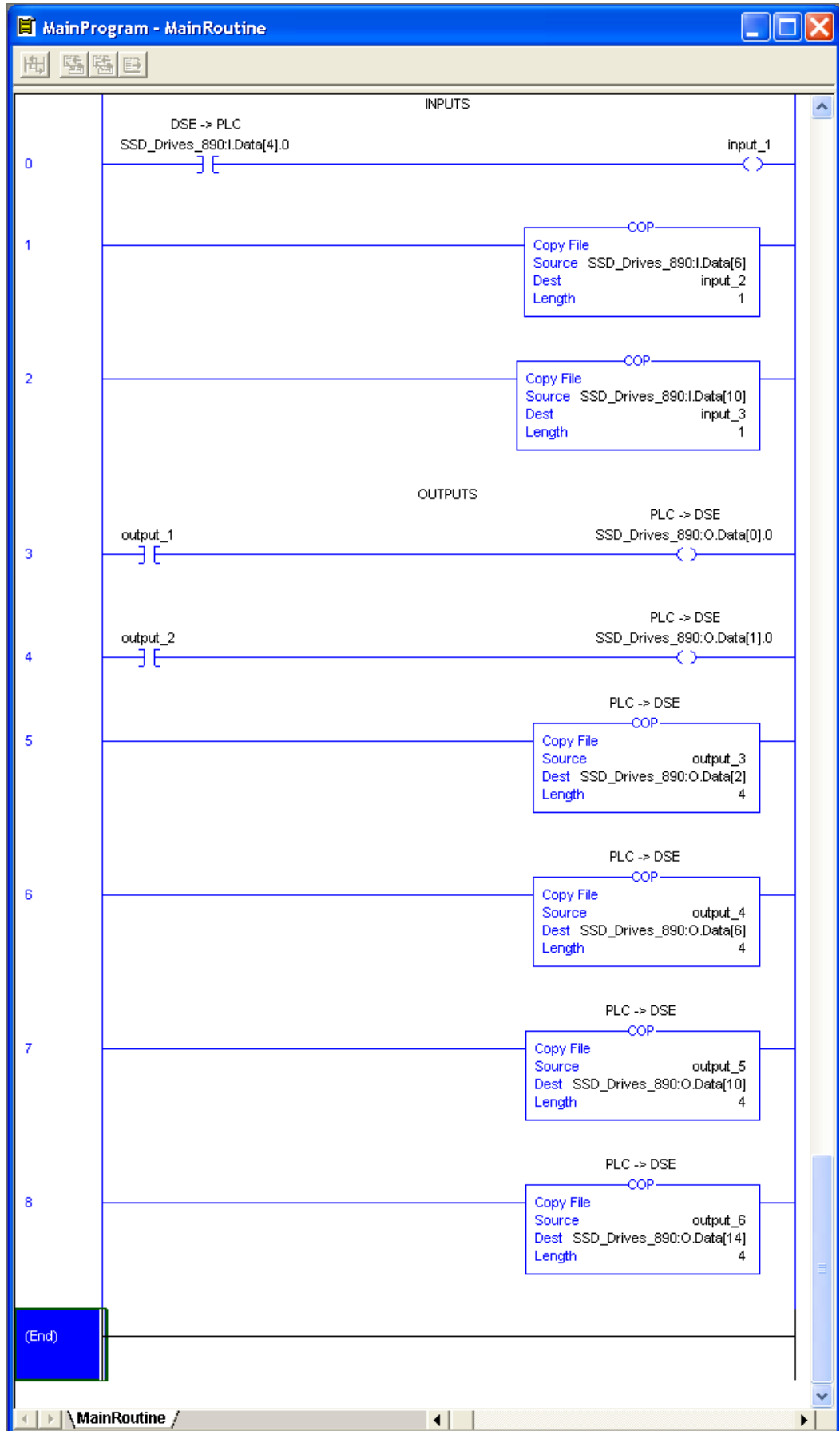

In the example below, the following new tags have been created:

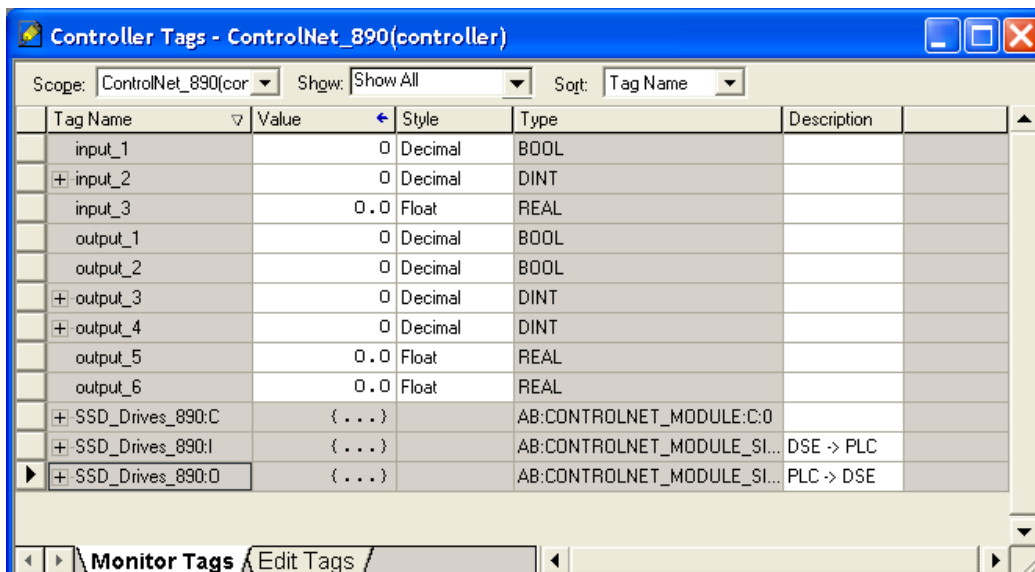

New Tag Name	New Tag Type	Copied From	Representing DSE Connector
Input_1	BOOL 1-bit	I.Data[4] bit 0	FLO.1
Input_2	DINT 32-bit	I.Data[6..9]	FIO.1
Input_3	REAL 32-bit	I.Data[10..13]	FVO.1

New Tag Name	New Tag Type	Copied To	Representing DSE Connector
Output_1	BOOL 1-bit	O.Data[0] bit 0	FLI.1
Output_2	BOOL 1-bit	O.Data[1] bit 0	FLI.2
Output_3	DINT 32-bit	O.Data[2..5]	FII.1
Output_4	DINT 32-bit	O.Data[6..9]	FII.2
Output_5	REAL 32-bit	O.Data[10..13]	FVI.1
Output_6	REAL 32-bit	O.Data[14..17]	FVI.2

Appendix A : Troubleshooting

890 ControlNet TechCard Status LEDs

Table 1









Colour	LED Indication	Description
 OFF	A & B : OFF	Drive is not initialised/fault
 RED	A & B : ON	Faulted TechCard - restart or repair
 RED/GREEN alternating	A & B : FLASH	Self-test routine
 RED/OFF	A & B : FLASH	Duplicate node address
 OFF	A or B : OFF	Disabled channel (depends on network configuration)
 GREEN	A or B : ON	NORMAL OPERATION OF CHANNEL
 GREEN/OFF	A or B : FLASH	Temporary error (drive will self- correct) or drive is not configured to go online (node address not set)
 RED/OFF	A or B : FLASH	Cabling fault, or no other drives (nodes) on the network
 RED/GREEN alternating	A or B : FLASH	Incorrect network configuration

Table 2

NETWORK STATES		
0	INVALID	Wrong Option Card / not fitted
1	POWER UP	Option Card not Commissioned
2	CHECK FOR CABLE	Inspect Cable for Continuity
3	WAIT TO ROGUE	Check if parameters match the network
4	CHECK FOR MODERATOR	Waiting for network parameters
5	IM ALIVE	Send "I'M ALIVE" message
6	ATTACHED	Communicating with Master
7	FORCED LISTEN ONLY	Receive Only Mode
8	DUP NODE	Duplicate Node Address

Appendix B : DSE/ControlNet Conversion Rules

The rules governing the conversion between DSE data types and ControlNet PLC data types are given below. Note carefully that some conversions will result in rounding, limiting and truncation of the original value. Certain conversions are not supported, however if used then data space will be allocated in the buffer, but a data value of zero will be returned.

LOGIC Type Connector

	Data from PLC	Data to DSE
From BOOL to LOGIC	False True	False True
From REAL to LOGIC	Not Supported Returns False	
From SINT to LOGIC	Zero Non-zero	False True
From INT to LOGIC	Zero Non-zero	False True
From DINT to LOGIC	Zero Non-zero	False True
From USINT to LOGIC	Zero Non-zero	False True
From UINT to LOGIC	Zero Non-zero	False True
From UDINT to LOGIC	Zero Non-zero	False True
From BYTE to LOGIC	Zero Non-zero	False True
From WORD to LOGIC	Zero Non-zero	False True
From DWORD to LOGIC	Zero Non-zero	False True

	Data from DSE	Data to PLC
From LOGIC to BOOL	False True	False True
From LOGIC to REAL	Not Supported Returns 0.0	
From LOGIC to SINT	False True	0 1
From LOGIC to INT	False True	0 1
From LOGIC to DINT	False True	0 1
From LOGIC to USINT	False True	0 1
From LOGIC to UINT	False True	0 1
From LOGIC to UDINT	False True	0 1
From LOGIC to BYTE	False True	0x00 0x01
From LOGIC to WORD	False True	0x0000 0x0001
From LOGIC to DWORD	False True	0x0000 0000 0x0000 0001

INTEGER Type Connector

	Data from PLC	Data to DSE
From BOOL to INTEGER	False True	0x0000 0000 0x0000 0001
From REAL to INTEGER	32-bit IEEE floating-point	-2,147,483,648 to 2,147,483,547 Fractional part rounded
From SINT to INTEGER	-128 to 127	-128 to 127
From INT to INTEGER	-32,768 to 32,767	-32,768 to 32,767
From DINT to INTEGER	-2,147,483,648 to 2,147,483,547	-2,147,483,648 to 2,147,483,547
From USINT to INTEGER	0 to 255	0 to 255
From UINT to INTEGER	0 to 65,535	0 to 65,535
From UDINT to INTEGER	0 to 4,294,967,295	0 to 2,147,483,647 limits apply
From BYTE to INTEGER	0x00 to 0xFF	0x0000 0000 to 0x0000 00FF
From WORD to INTEGER	0x0000 to 0xFFFF	0x0000 0000 to 0x0000 FFFF
From DWORD to INTEGER	0x0000 0000 to 0xFFFF FFFF	0x0000 0000 to 0xFFFF FFFF

	Data from DSE	Data to PLC
From INTEGER to BOOL	Zero Non-zero	True False
From INTEGER to REAL	-2,147,483,648 to 2,147,483,647	32-bit IEEE floating- point
From INTEGER to SINT	-2,147,483,648 to 2,147,483,647	-128 to 127 limits apply
From INTEGER to INT	-2,147,483,648 to 2,147,483,647	-32768 to 32767 limits apply
From INTEGER to DINT	-2,147,483,648 to 2,147,483,647	-2,147,483,648 to 2,147,483,647
From INTEGER to USINT	-2,147,483,648 to 2,147,483,647	0 to 255 limits apply
From INTEGER to UINT	-2,147,483,648 to 2,147,483,647	0 to 65,535 limits apply
From INTEGER to UDINT	-2,147,483,648 to 2,147,483,647	0 to 2,147,483,647 limits apply
From INTEGER to BYTE	0x0000 0000 to 0xFFFF FFFF	0x00 to 0xFF truncation applies
From INTEGER to WORD	0x0000 0000 to 0xFFFF FFFF	0x0000 to 0xFFFF truncation applies
From INTEGER to DWORD	0x0000 0000 to 0xFFFF FFFF	0x0000 0000 to 0xFFFF FFFF

VALUE Type Connector

	Data from PLC	Data to DSE
From BOOL to VALUE	Not Supported Returns 0.0	
From REAL to VALUE	32-bit IEEE floating-point	-32,768.0 to 32,767.9999 limits apply
From SINT to VALUE	-128 to 127	-128.0 to 127.0
From INT to VALUE	-32,768 to 32,767	-32,768.0 to 32,767.0
From DINT to VALUE	-2,147,483,648 to 2,147,483,547	-32,768.0 to 32,767.0 limits apply
From USINT to VALUE	0 to 255	0.0 to 255.0
From UINT to VALUE	0 to 65,535	0.0 to 32,767.0 limits apply
From UDINT to VALUE	0 to 4,294,967,295	0.0 to 32,767.0 limits apply
From BYTE to VALUE	Not Supported Returns 0.0	
From WORD to VALUE	Not Supported Returns 0.0	
From DWORD to VALUE	Not Supported Returns 0.0	

	Data from DSE	Data to PLC
From VALUE to BOOL	Not Supported Returns false	
From VALUE to REAL	-32,768.0 to 32,767.9999	32-bit IEEE floating-point
From VALUE to SINT	-32,768.0 to 32,767.9999	-128 to 127 limits apply/ rounding applies
From VALUE to INT	-32,768.0 to 32,767.9999	-32,768 to 32,767 limits apply/ rounding applies
From VALUE to DINT	-32,768.0 to 32,767.9999	-32768 to 32,767 limits apply/ rounding applies
From VALUE to USINT	-32,768.0 to 32,767.9999	0 to 255 limits apply/ rounding applies
From VALUE to UINT	-32,768.0 to 32,767.9999	0 to 32767 limits apply/ rounding applies
From VALUE to UDINT	-32,768.0 to 32,767.9999	0 to 32767 limits apply/ rounding applies
From VALUE to BYTE	Not Supported Returns 0x00	
From VALUE to WORD	Not Supported Returns 0x0000	
From VALUE to DWORD	Not Supported Returns 0x0000 0000	

ISS.	MODIFICATION	ECN No.	DATE	DRAWN	CHK'D
1	Initial Issue (HA469263U001)	17320	29/04/05	CM	MF
2	Various small amendments.	17320	03/06/05	CM	MF
FIRST USED ON		MODIFICATION RECORD			
		8903/CN ControlNet Communications Interface			
		DRAWING NUMBER			SHT. 1
		ZZ469263C001			OF 1