



8902/RE

Resolver Speed Feedback

Option

Technical Manual

HA469251U001 Issue 1

Compatible with Version 1.x Software

© Copyright 2005 SSD Drives Limited (formerly Eurotherm Drives Limited)

All rights strictly reserved. No part of this document may be stored in a retrieval system, or transmitted in any form or by any means to persons not employed by an SSD Drives company without written permission from SSD Drives Ltd.

Although every effort has been taken to ensure the accuracy of this document it may be necessary, without notice, to make amendments or correct omissions. SSD Drives cannot accept responsibility for damage, injury, or expenses resulting therefrom.

Safety Information



WARNING!

During commissioning, remove the fuses (or trip the circuit breaker) on your 3-phase supply.
Make sure the power is OFF, and that it cannot be switched on accidentally whilst you are working.

Please read this information BEFORE installing the equipment.

Intended Users

This manual is to be made available to all persons who are required to install, configure or service equipment described herein, or any other associated operation.

The information given is intended to highlight safety issues, and to enable the user to obtain maximum benefit from the equipment.

Application Area

The equipment described is intended for industrial motor speed control utilising AC induction or AC synchronous machines.

Personnel

Installation, operation and maintenance of the equipment should be carried out by qualified personnel. A qualified person is someone who is technically competent and familiar with all safety information and established safety practices; with the installation process, operation and maintenance of this equipment; and with all the hazards involved.

REFER TO YOUR MAIN PRODUCT MANUAL FOR SPECIFIC SAFETY INFORMATION ABOUT THE DEVICE YOU ARE CONTROLLING

WARRANTY

SSD Drives warrants the goods against defects in design, materials and workmanship for the period of 12 months from the date of delivery on the terms detailed in SSD Drives Standard Conditions of Sale IA058393C.

SSD Drives reserves the right to change the content and product specification without notice.

Contents

Contents

Page

RESOLVER SPEED FEEDBACK OPTION	1
Description	1
• Features	1
• Part Number	1
• Used On	1
• Specifications.....	1
Recommended Spare Parts	1
Installation	2
Fitting the Option	2
Wiring the System	3
• D-Type Connections	3
Resolver Diagram	4
Approved Resolvers.....	4
Initial Set-up	5
Configuring the 890 Drive.....	5
• RESOLVER Function Block.....	5
Motor Phasing	7

RESOLVER SPEED FEEDBACK OPTION

Description

The 8902/RE Resolver Speed Feedback Option allows resolvers to be connected directly to the motor controller to provide highly accurate speed feedback measurement.

Features

The Option has the following features:

- Contains two differential inputs on channels Sin and Cos
- Contains a carrier output signal to power the Resolver

Part Number

The part number for the Resolver Speed Feedback Option is :

8902/RE/00/00

8902/RE/00/FF (indicates a factory-fitted Option)

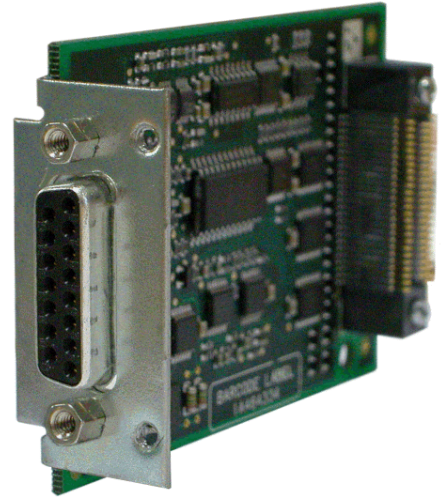

Figure 1 Resolver Speed Feedback Option

Used On

This Option can be used on 890 drives with the following Product Codes:

890SD/.. 890SD Standalone Drive

890CD/.. 890CD Common Bus Drive

Refer to the 890 Engineering Reference Manual, Appendix E for Product Code details.

Specifications

Maximum Speed	Up to 50,000RPM (with 2 pole resolver)
Carrier Output Signal	7Vrms, 8kHz
Maximum Carrier Supply	70mA rms
Maximum Input Voltage	$\pm 12V$ peak
Accuracy	< 5 minutes
Resolution	Equivalent of 16 bits in one revolution of electrical resolver turn
Inputs	Differential inputs, $Z_{in} \sim 2 k\Omega$ Maximum input voltage : 12Vpeak

Recommended Spare Parts

We recommend that you keep one Option as a spare to reduce down-time.

Installation

Fitting the Option

If the Option is not factory-fitted, follow the procedure given below.

WARNING!

Disconnect all sources of power before attempting installation.

Caution

This Option contains ESD (Electrostatic Discharge) sensitive parts. Observe static control precautions when handling, installing and servicing this Option.

1. Undo the two screws securing Option A and Option B to the front of the drive. If Options are not fitted, completely remove the blank covers for the Option A and Option B slots.
2. Undo the screws (A) located in the top and bottom handles of the control board. Gently pull on the handles to withdraw the board from the drive, supporting any attached option boards. Note that the boards are sliding in top and bottom slots.
3. Remove any other Options that are fitted to the control board.
4. Offer up the Resolver Option through the "OPTION F" cut-out as shown opposite.
5. Fit the two locating pegs of the large connector on the rear edge of the option board into the locating holes on the control board, as shown below.
6. Secure with the two screws (B) to the front of the control board.
7. Fit the two screws (C) and washers at the rear edge of the Option.
8. Refit any other Options that were removed from the control board.
9. Replace the control board (with attached Options) into the drive.
10. Tighten the Option A and Option B screws; or importantly, fit the blank covers and secure with the screws.

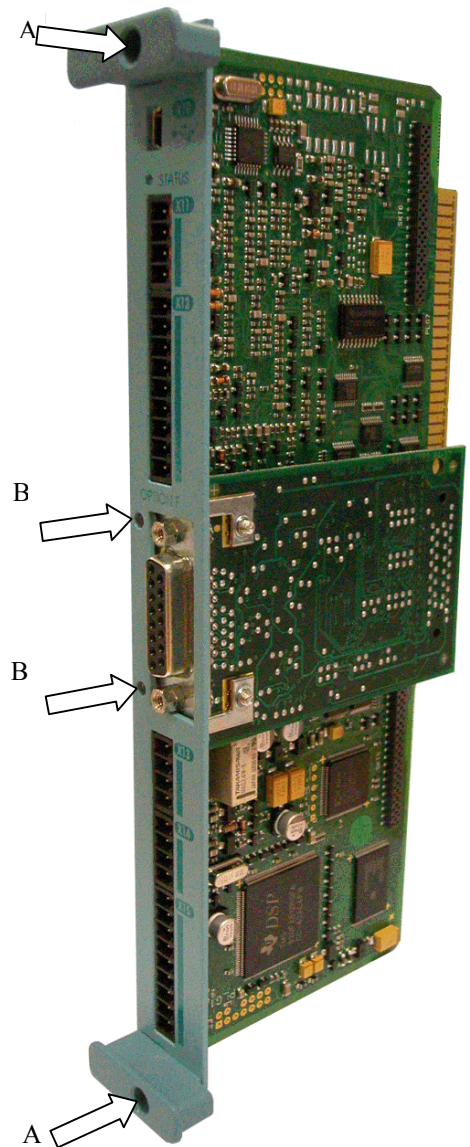

Figure 2 Control board showing Option correctly mounted



Figure 3 Rear of Control Board

Wiring the System

WARNING!
Disconnect all sources of power before attempting installation.

Caution

This Option contains ESD (Electrostatic Discharge) sensitive parts. Observe static control precautions when handling, installing and servicing this Option.

D-Type Connections

Note: For correct operation, carrier, sine and cosine **must** be connected as specified. Poor performance/motor behaviour may occur if these signals are left unconnected or are connected incorrectly.

Take special care wiring the resolvers to the Option due to the low level of the signals.

Ideally use twisted-pair, screened cable with an overall screen and a screen over each individual pair. It may be possible to use a cable with just a screen over each individual pair. The signal pairs should have characteristic impedance of 120Ω. To ensure compliance with the EMC Directive the overall cable screen should be connected to the connector body and to the cable clamp. Connect overall screen and individual screens together, on each side of the cable.

Use the resolver manufacturer's recommended cable.

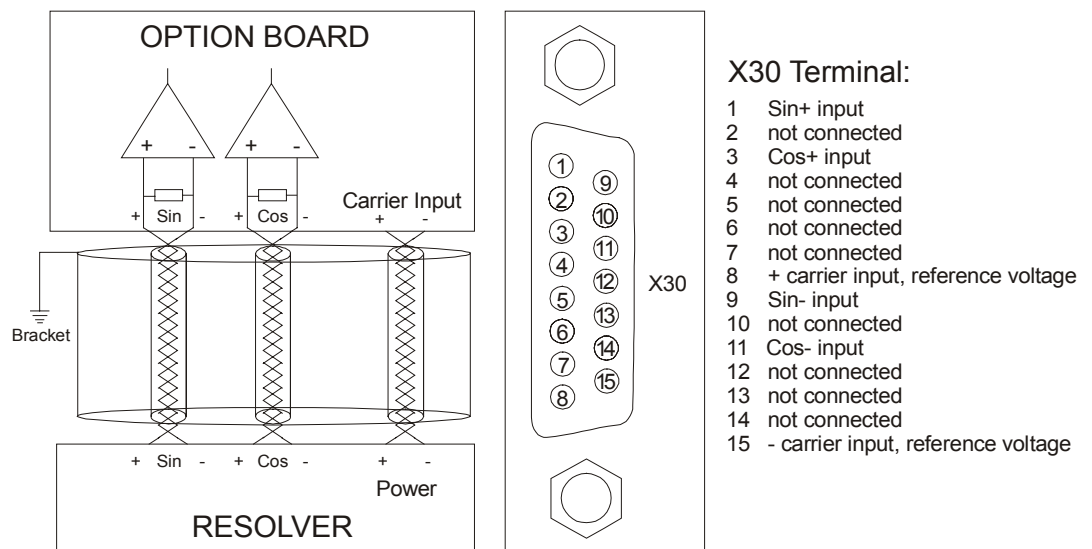
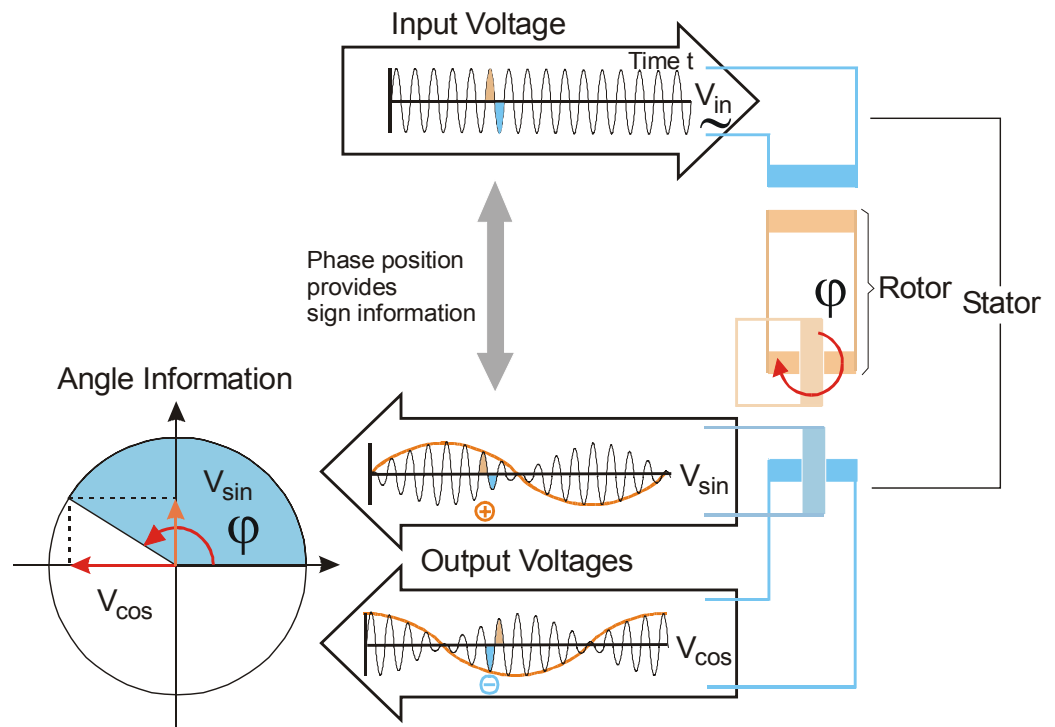

Figure 4 Wiring Diagram

Resolver Diagram



COSINE input : $V_{\cos} = V(S1-S3) = V(R1-R2) \times TR \times \cos\theta$

SINE input : $V_{\sin} = V(S2-S4) = V(R1-R2) \times TR \times \sin\theta$

With : $V_{in} = V(R1-R2)$: carrier signal (reference voltage)

TR = transformation ratio

ϕ = position

Approved Resolvers

SSD Drives approve the following Resolvers for use with the 8902/RE Speed Feedback Option.

Tamagawa TS2610N71E64

Tamagawa TS2620N701E11

Tamagawa TS2620N861E11

Tamagawa TS2640N821E64

Initial Set-up

Configuring the 890 Drive

Note: The DSE 890 Configuration Tool is SSD Drives' Windows-based block programming software and is supplied with each drive.

Use the DSE 890 Configuration Tool to configure the RESOLVER function block, as detailed below.

You will require a PMAC (Permanent Magnet AC) Configuration when using DSE 890: create a "New Configuration" in DSE 890 and select "890 Permanent Magnet AC" in the dialog box. Double-click on the MOTOR CONTROL function block in the new configuration to display the RESOLVER function block.

DSE 890 offers a "Motor Wizard" to quickly enter parameter information into the RESOLVER function block: from the menu at the top of the screen select Edit → Motor Wizard. In the pop-up dialog box you can now select the motor and resolver from the drop-down lists.

Alternatively, you can enter parameter information directly into the RESOLVER function block. The parameters are described below.

RESOLVER Function Block

SETUP::MOTOR CONTROL::RESOLVER

This block allows Speed Feedback to be measured using a resolver.

Note: Only parameters relevant to the Resolver are described below.

Parameter Descriptions	
NAME	Range:
Resolver name/designation	
POLES	Range: 2 to 20
Number of resolver poles. In case of multi-pair poles resolver, the resolution of the resolver option is multiplied by the number of pair poles.	
RATIO	Range: 0.2 to 1.0
Transformation ratio of the resolver	
SPEED MAX	Range: 0 to 2 ³¹ (user units)
Mechanical maximum speed supported by the resolver.	
ACCURACY	Range: 0 to 60.0 minutes
This parameter represents the nominal accuracy of the resolver. (This information is only informative and could be left unspecified).	
CARRIER VOLTAGE	Range: 5.0 to 10.0 Vrms
This parameter represents the nominal carrier voltage for the resolver. (This information is only informative and could be left unspecified).	
CURRENT	Range: 0.0 to 70mA rms
This information represents the nominal current needed to run the resolver. (This information is only informative and could be left unspecified).	
INERTIA	Range: 10.0 to 100000 Kgcm ²
This information represents the resolver rotor inertia. (This information is only informative and could be left unspecified).	

Parameter Descriptions

TRIP

Range: FALSE-TRUE

This information gives the resolver processing state :

- TRUE : the drive has tripped. Verify the connection of the resolver.
- FALSE : the system is able to run. The position and speed information are available.

POSITION SET UP

Range : - 180° to 180°

Relative position between the position 0 degree from the resolver and the Parvex convention for the motor phasing.

Refer to "Motor Phasing" below.

INIT DONE

Range: FALSE-TRUE

This information gives the resolver processing init state :

- TRUE : the resolver processing is running, the init state is completed and the speed and position information are normally available
- FALSE : the initialisation phase is on-going. Position and speed information are not available.

The initialisation phase could be viewed :

- at power on,
- after a trip and reset action.

REVERSE CNT DIR

Range: FALSE-TRUE

This input allows you to reverse the counting direction of the resolver feedback.

FALSE : counting direction is positive when the motor spins in a clockwise direction, looking to the front shaft of the motor

TRUE : counting direction is negative when the motor spins in a clockwise direction, looking to the front shaft of the motor

SPEED FILTER

Range : 10.0 to 1000.0 Hz

This input allows you to select the cutting frequency of the first order low pass filter applied to the resolver speed output.

Motor Phasing

The control of PMAC brushless motors is allowed if the relative position between the stator and the rotor is well known. The resolver must be set up to define the relative position between the resolver and the 3 motor phases. For the 890 drive, the convention is as follows :

- ◆ when the motor runs in a clockwise direction, looking to the front shaft of the motor, the 3 successive phases are M1, M2 and M3 as shown below.

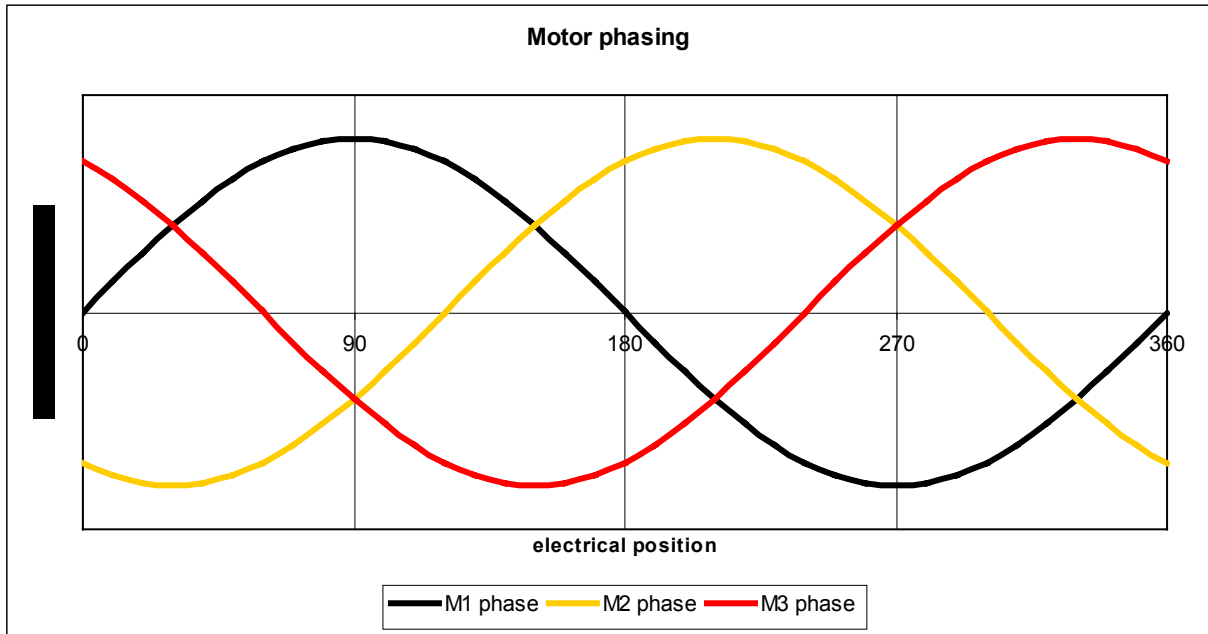

- ◆ The resolver must be adjusted in a way to give a position of 0 degrees when the M1 motor phase crosses the 0 Volt line in a rising variation. For example, a 6 pole motor associated with a 2 pole resolver will give the following curves:

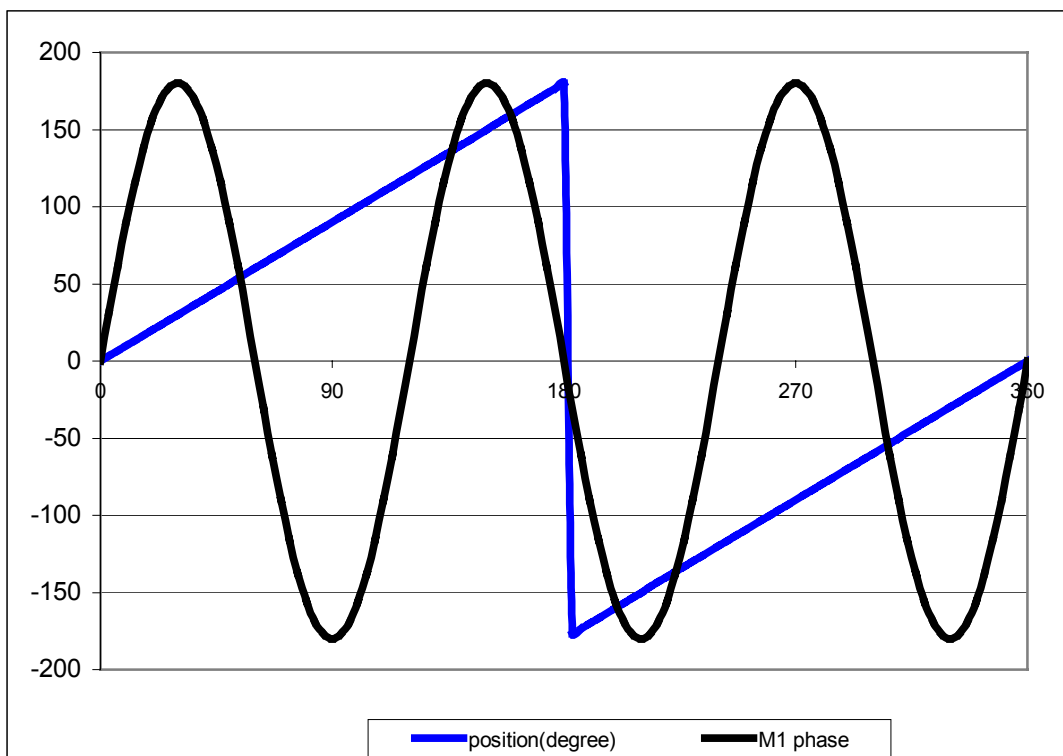

ISS.	MODIFICATION	ECN No.	DATE	DRAWN	CHK'D
1	Initial Issue (HA469251U001)	17320	20/06/05	CM	GO
FIRST USED ON		MODIFICATION RECORD 8902/RE Resolver Speed Feedback Option			
		DRAWING NUMBER ZZ469251C001			SHT. 1 OF 1