



650V AC Drive

Frame 1, 2 & 3

Product Manual

HA467649U002 Issue 5

Compatible with Version 4.8 Software onwards

© Copyright 2005 SSD Drives Limited (formerly Eurotherm Drives Limited)

All rights strictly reserved. No part of this document may be stored in a retrieval system, or transmitted in any form or by any means to persons not employed by an SSD Drives company without written permission from SSD Drives Ltd.

Although every effort has been taken to ensure the accuracy of this document it may be necessary, without notice, to make amendments or correct omissions. SSD Drives cannot accept responsibility for damage, injury, or expenses resulting therefrom.

WARRANTY

SSD Drives warrants the goods against defects in design, materials and workmanship for the period of 12 months from the date of delivery on the terms detailed in SSD Drives Standard Conditions of Sale IA058393C.

SSD Drives reserves the right to change the content and product specification without notice.

Safety Information



Requirements

IMPORTANT: Please read this information BEFORE installing the equipment.

Intended Users

This manual is to be made available to all persons who are required to install, configure or service equipment described herein, or any other associated operation.

The information given is intended to highlight safety issues, and to enable the user to obtain maximum benefit from the equipment.

Complete the following table for future reference detailing how the unit is to be installed and used.

INSTALLATION DETAILS	
Serial Number <i>(see product label)</i>	
Where installed <i>(for your own information)</i>	
Unit used as a: <i>(refer to Certification for the Inverter)</i>	<input type="checkbox"/> Component <input type="checkbox"/> Relevant Apparatus
Unit fitted:	<input type="checkbox"/> Wall-mounted <input type="checkbox"/> Enclosure

Application Area

The equipment described is intended for industrial motor speed control utilising AC induction or AC synchronous machines.

Personnel

Installation, operation and maintenance of the equipment should be carried out by qualified personnel. A qualified person is someone who is technically competent and familiar with all safety information and established safety practices; with the installation process, operation and maintenance of this equipment; and with all the hazards involved.

Safety Information



Hazards

WARNING!

This equipment can endanger life through rotating machinery and high voltages. Failure to observe the following will constitute an ELECTRICAL SHOCK HAZARD. This is a product of the restricted sales distribution class according to IEC 61800-3. In a domestic environment this product may cause radio interference in which case the user may be required to take adequate measures. This product is designated as "professional equipment" as defined in EN61000-3-2. Permission of the supply authority shall be obtained before connection to the low voltage supply.

- The equipment must be **permanently earthed** due to the high earth leakage current.
- The drive motor must be connected to an appropriate safety earth.
- The equipment contains high value capacitors which take time to discharge after removal of the mains supply.
- Before working on the equipment, ensure isolation of the mains supply from terminals L1, L2 and L3. Wait for at least 5 minutes for the dc link terminals (DC+ and DC-) to discharge to safe voltage levels (<60V). Measure the DC+ and DC- terminal voltage with a meter to confirm that the voltage is less than 50V.
- Never perform high voltage resistance checks on the wiring without first disconnecting the drive from the circuit being tested.
- When replacing a drive in an application and before returning to use, it is essential that all user defined parameters for the product's operation are correctly installed.
- This equipment contains electrostatic discharge (ESD) sensitive parts. Observe static control precautions when handling, installing and servicing this product.

IMPORTANT: Metal parts may reach a temperature of 90 degrees centigrade in operation.

Application Risk

The specifications, processes and circuitry described herein are for guidance only and may need to be adapted to the user's specific application.

SSD Drives does not guarantee the suitability of the equipment described in this Manual for individual applications.

Risk Assessment

Under fault conditions, power loss or other operating conditions not intended, the equipment may not operate as specified. In particular:

- The motor speed may not be controlled
- The direction of rotation of the motor may not be controlled
- The motor may be energised

Guards

The user must provide guarding and /or additional safety systems to prevent risk of injury and electric shock.

Protective Insulation

- All control and signal terminals are SELV, i.e. protected by double insulation. Ensure all wiring is rated for the highest system voltage.

Note: Thermal sensors contained within the motor must be double insulated.

- All exposed metalwork in the Inverter is protected by basic insulation and bonding to a safety earth.

RCDs

These are not recommended for use with this product but, where their use is mandatory, only Type B RCDs should be used.

650V Quick Start

- Mount the drive vertically in a lockable cubicle.
- Is the drive to operate in Local (using the keypad) or Remote Control?
If Remote Control, make Control Connections.
- Make Power Connections. Power-on and follow the Quick Set-Up procedure.
- Apply a small setpoint. Start and stop the motor.

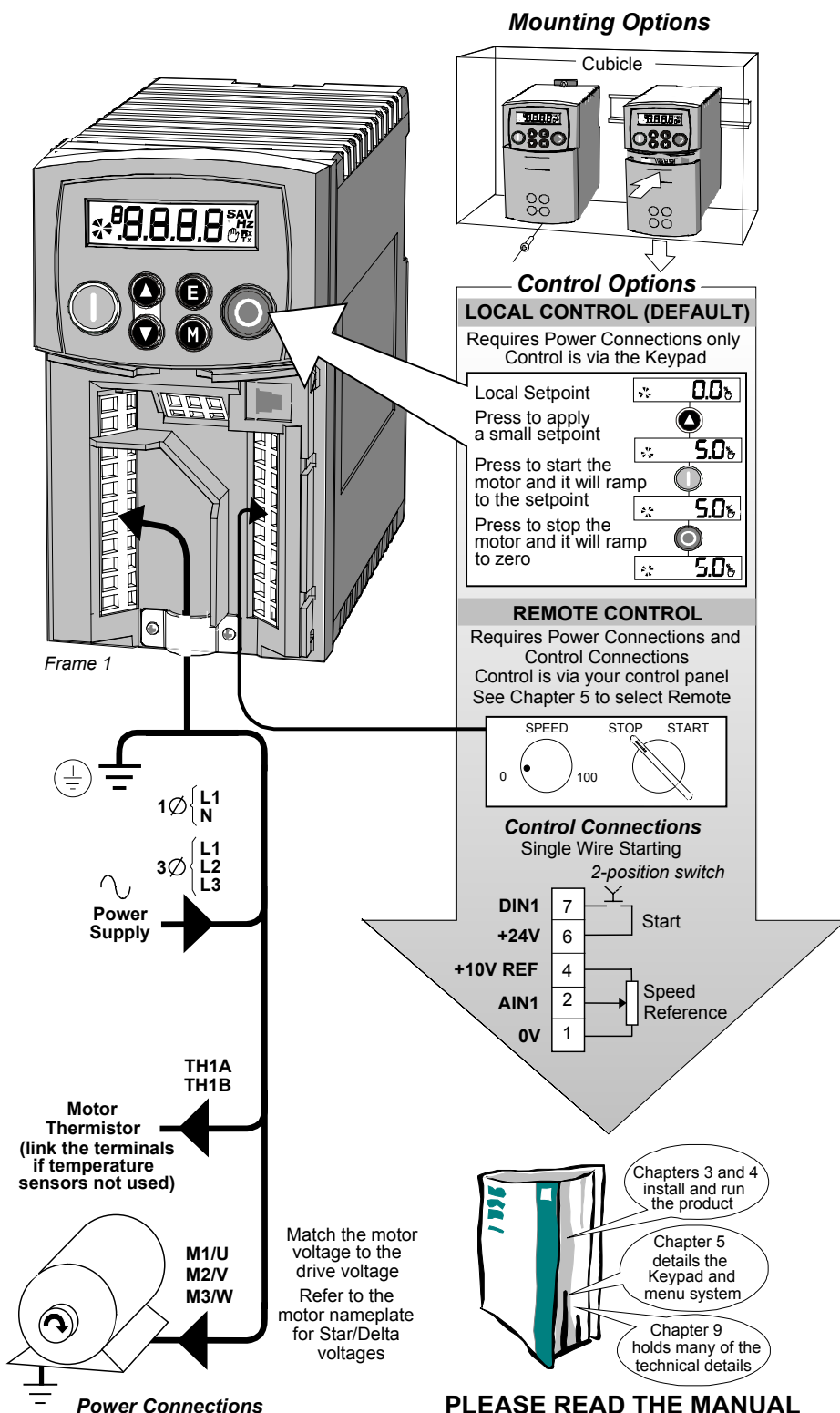

Mounting Options

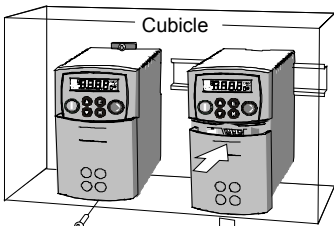

Control Options

LOCAL CONTROL (DEFAULT)

Requires Power Connections only
Control is via the Keypad

Local Setpoint	0.0%
Press to apply a small setpoint	5.0%
Press to start the motor and it will ramp to the setpoint	5.0%
Press to stop the motor and it will ramp to zero	5.0%

REMOTE CONTROL

Requires Power Connections and Control Connections
Control is via your control panel
See Chapter 5 to select Remote

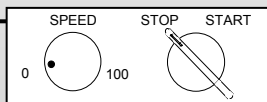

Control Connections

Single Wire Starting
2-position switch

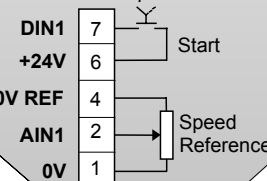

Quick Set-Up

Hold the M key until DIAG is displayed

Navigate to the PAR menu

Press to enter the menu and see the first parameter

Press to show the next parameter

Press to edit the MAX SPEED parameter

Adjust MAX SPEED

Press to exit the parameter

Press (4 times) to show P6

Press to edit the MOTOR CURRENT parameter

Adjust MOTOR CURRENT
Refer to motor nameplate

Press to exit the parameter

Press to show P7

Press to edit the BASE FREQUENCY parameter

Adjust BASE FREQUENCY

Press (3 times) to display the Local Setpoint

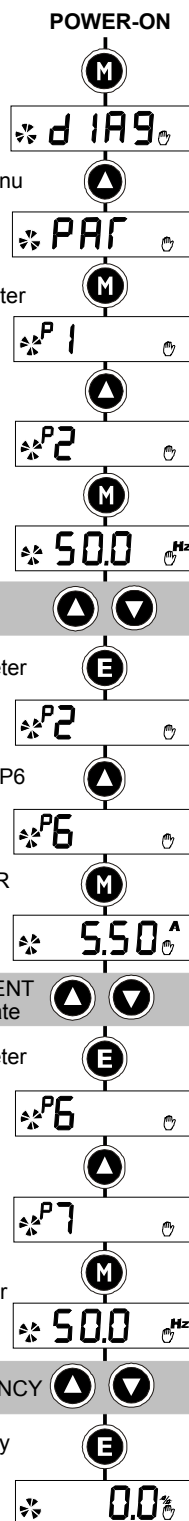

PLEASE READ THE MANUAL

Contents

<i>Contents</i>	<i>Page</i>
Chapter 1 GETTING STARTED	
Introduction	1-1
Equipment Inspection	1-1
Storage and Packaging	1-1
About this Manual	1-1
• Software Product Manual	1-1
Chapter 2 AN OVERVIEW OF THE DRIVE	
Component Identification	2-1
Chapter 3 INSTALLING THE DRIVE	
Mechanical Installation	3-1
Mounting the Drive.....	3-1
Ventilation	3-1
Electrical Installation	3-2
Wiring Instructions.....	3-2
• Local Control Wiring.....	3-2
• Remote Control Wiring	3-2
Connection Diagram.....	3-3
• Control Wiring Connections	3-4
• Power Wiring Connections	3-4
• Terminal Block Acceptance Sizes	3-5
Optional Equipment	3-6
• Fitting the Remote 6511 Keypad.....	3-6
• Fitting the Remote 6521/6901 Keypad	3-7
• RS485/RS232 Communication Module.....	3-8
• Encoder Connections	3-9
• Line Choke.....	3-10
Chapter 4 OPERATING THE DRIVE	
Pre-Operation Checks	4-1
Initial Start-up Routines	4-1
Local Control Operation.....	4-2
Remote Control Operation	4-2
Set-up as an Open-loop drive (V/F Mode)	4-3
Set-up using the Sensorless Vector Mode	4-3
• Autotuning the Drive	4-4
Tuning the Drive to Your System.....	4-5
Chapter 5 THE KEYPAD	
Controlling the Drive using the Keypad	5-1
Control Key Definitions.....	5-1
Display Indications	5-2
Drive Status Indications.....	5-2

Contents

<i>Contents</i>	<i>Page</i>
The DIAGNOSTICS Menu	5-2
The Menu System	5-3
How To Change a Parameter Value	5-4
Special Menu Features	5-4
Resetting to Factory Defaults (2-button reset).....	5-4
Changing the Drive Operating Frequency	5-4
Selecting Local or Remote Control.....	5-4
Password Protection	5-5
Quick Application Selection	5-5
Selecting the Menu Detail	5-5
Chapter 6 PROGRAMMING YOUR APPLICATION	
MMI Parameters	6-1
• Configuring Terminals 9 & 10 (Digital Input/Output)	6-13
• PID - Tuning Your Drive	6-13
• Auto Restart.....	6-14
• Skip Frequencies.....	6-15
• Minimum Speed Mode.....	6-16
Product-Related Default Values	6-16
• * Frequency Dependent Parameters	6-16
• ** Power Dependent Parameters.....	6-18
Chapter 7 TRIPS AND FAULT FINDING	
Trips	7-1
Trip Warning Message	7-1
What Happens when a Trip Occurs.....	7-1
Resetting a Trip Condition.....	7-1
Using the Keypad to Manage Trips.....	7-1
Hexadecimal Representation of Trips.....	7-5
Fault Finding.....	7-6
Chapter 8 ROUTINE MAINTENANCE AND REPAIR	
Routine Maintenance.....	8-1
Repair	8-1
Saving Your Application Data	8-1
Returning the Unit to SSD Drives	8-1
Disposal	8-1
Chapter 9 TECHNICAL SPECIFICATIONS	
Understanding the Product Code	9-1
• Model Number (Europe).....	9-1
• Catalog Number (North America).....	9-2
Environmental Details.....	9-3
Power Details.....	9-3

Contents

<i>Contents</i>	<i>Page</i>
Electrical Ratings	9-4
User Relay	9-5
Analog Inputs/Outputs	9-5
Digital Inputs	9-5
Digital Outputs	9-5
Cabling Requirements for EMC Compliance	9-6
Internal Dynamic Braking Circuit.....	9-6
External Brake Resistor	9-7
Supply Harmonic Analysis (230V filtered)	9-8
Supply Harmonic Analysis (400V filtered)	9-9
Supply Harmonic Analysis (230V unfiltered).....	9-10
Supply Harmonic Analysis (400V unfiltered).....	9-11

Chapter 10 CERTIFICATION FOR THE DRIVE

Requirements for EMC Compliance	10-1
Earthing Requirements.....	10-1
Requirements for UL Compliance	10-1
European Directives and the CE Mark.....	10-3
CE Marking for Low Voltage Directive	10-3
CE Marking for EMC - Who is Responsible?	10-3
EMC Compliance	10-3
Certificates	10-4

CHAPTER 11 SERIAL COMMUNICATIONS

Connection to the P3 Port	11-1
--	-------------

Chapter 12 THE DEFAULT APPLICATION

The Default Application	12-1
How to Load an Application	12-1
Application Description	12-1
Control Wiring for Applications.....	12-1
Application 1 : Basic Speed Control (default)	12-2
Application 2 : Auto/Manual Control	12-4
Application 3 : Preset Speeds.....	12-6
Application 4 : Raise/Lower Trim.....	12-8
Application 5 : PID	12-10

GETTING STARTED

Introduction

The 650V Series AC Drive provides simple, compact, and low-cost speed control for 3-phase induction motors

This manual describes the low-power end of the 650V product range for the following motor power ratings:

	Nominal Input Voltage	Phase	Drive Power	
Frame 1	230V	1	0.25 – 0.75kW	0.3 - 1.0 Hp
Frame 2	230V	1	1.1 – 1.5kW	1.5 - 2.0 Hp
Frame 2	400V	3	0.37 – 2.2kW	0.5 - 3.0 Hp
Frame 3	230V	3	2.2 - 4.0 kW	3.0 - 5.0 Hp
Frame 3	400V	3	3.0 – 7.5kW	4.0 - 10.0 Hp

The drive features:

- Local or Remote mode operation
- SELV control terminals (Safe Extra Low Volts)
- Intelligent monitoring strategy to avoid nuisance tripping
- In-built protection of the unit against overloads, excessive voltages, phase-to-phase and phase-to-earth short circuits
- An internal RFI filter is fitted as standard
- An internal dynamic brake switch for connection to an external resistor (400V units only)
- Quiet operation
- Controlling the unit locally using the 6511 Keypad gives access to parameters, diagnostic messages, trip settings and full application programming. Other features also become available, such as the advanced sensorless vector control scheme which gives high torque, low speed operation; selectable switching frequencies; and a unique Quiet Pattern control system that minimises audible noise from the motor.

Note: Do not attempt to control motors whose rated current is less than 50% of the drive rated current. Poor motor control or Autotune problems may occur if you do

Equipment Inspection

- Check for signs of transit damage
- Check the drive is suitable for your requirements by reading the Product Code on the rating label. Refer to Chapter 9: “Technical Specifications” - Understanding the Product Code.

If the unit is damaged, refer to Chapter 8: “Routine Maintenance and Repair” for information on returning damaged goods.

Storage and Packaging

Save the packaging in case of return. Improper packaging can result in transit damage.

If the unit is not being installed immediately, store the unit in a well-ventilated place away from high temperatures, humidity, dust or metal particles.

About this Manual

This manual is intended for use by the installer, user and programmer of the drive. It assumes a reasonable level of understanding in these three disciplines.

Note: Please read all Safety Information before proceeding with the installation and operation of this unit.

It is important that you pass the manual on to any new user of this unit.

Software Product Manual

An accompanying Software Product Manual is available for download from the SSD Drives website: www.SSDdrives.com.

AN OVERVIEW OF THE DRIVE

Component Identification

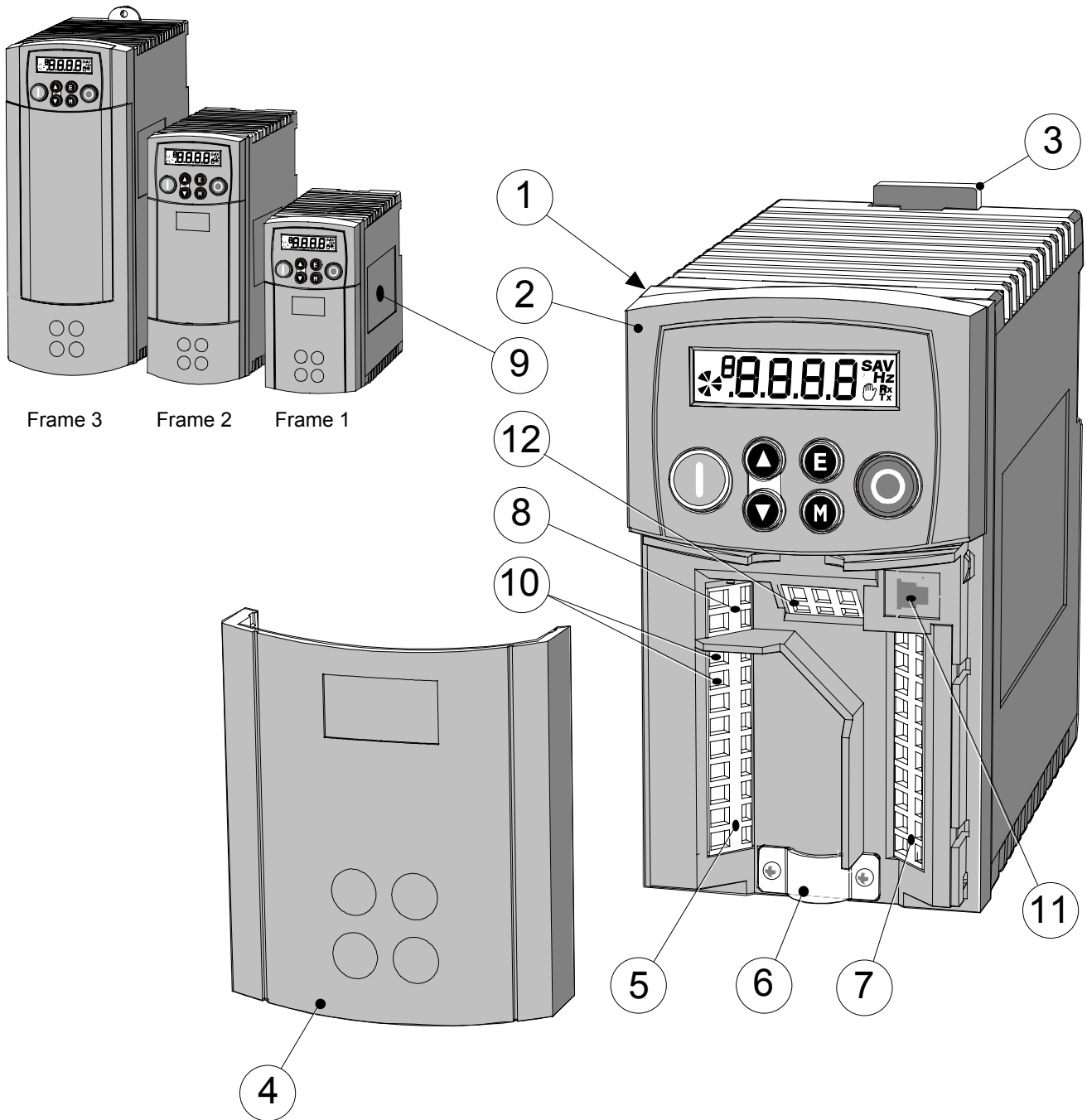

Figure 2-1 View of Component Parts (Frame 1 illustrated)

1	Main drive assembly	7	Control terminals
2	Keypad	8	Volt-free relay contacts
3	DIN clip/fixing bracket	9	Product rating label
4	Terminal cover	10	Motor thermistor terminals
5	Power terminals	11	RS232 programming port - P3
6	Motor cable screen clamp	12	Encoder/digital inputs

INSTALLING THE DRIVE

IMPORTANT: Read Chapter 10: "Certification for the Drive" before installing this unit.

Mechanical Installation

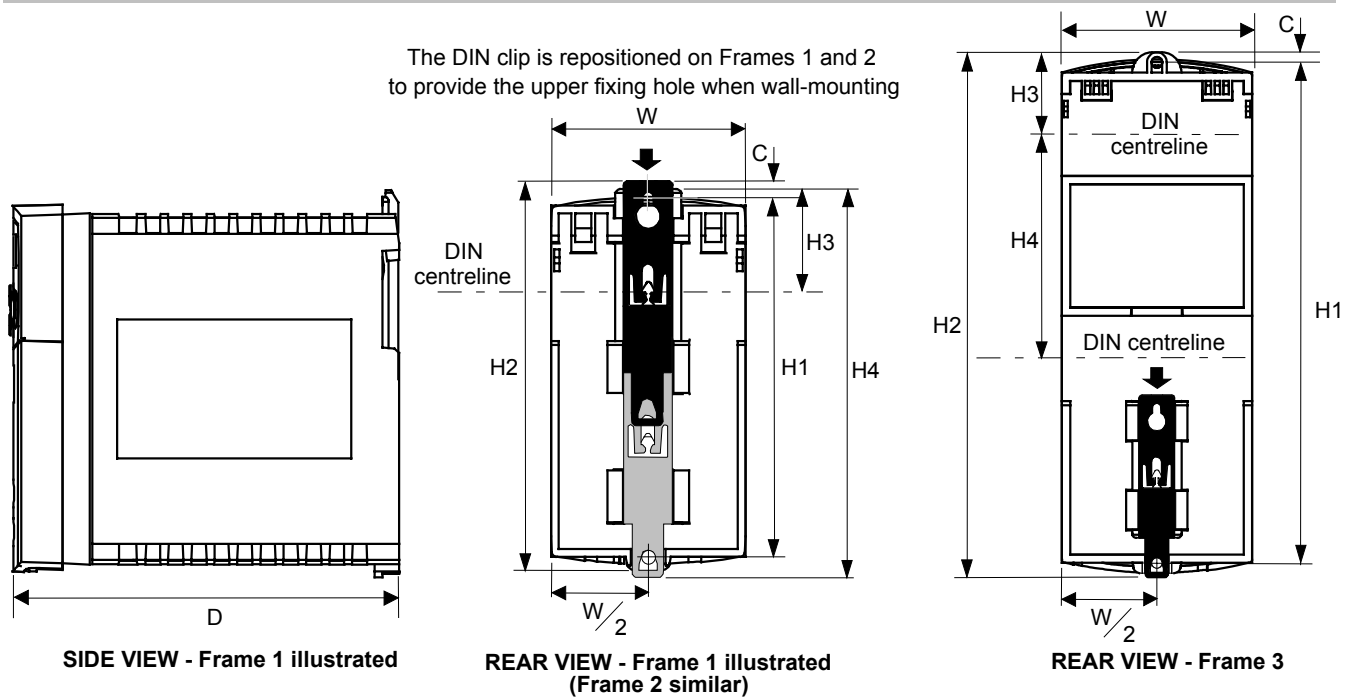

	Fixing	Torque	Weight	H1 Fixing Centres	H2	H3	H4	C	W	D
Frame 1	M4	1.5Nm	0.85kg (2 lbs)	132 (5.2")	143 (5.6")	35 (1.4")	139 (5.5")	6 (0.2")	73 (2.9")	142 (5.6")
Frame 2	M5	3.0Nm	1.4kg (3 lbs)	188 (7.4")	201 (7.9")	35 (1.4")	194 (7.7")	6.5 (0.24")	73 (2.9")	173 (6.8")
Frame 3	M5	3.0Nm	2.7kg (6 lbs)	242 (9.5")	260 (10.2")	38 (1.5")	112 (4.4")	5 (0.2")	96 (3.8")	200 (7.9")

Dimensions are in millimetres (inches)

Mounting the Drive

To maintain compliance with European Electrical Safety Standard VDE0160(1994)/EN50178 (1998) the unit must be mounted inside a control cubicle that requires a tool for opening. The cubicle should provide 15dB attenuation to radiated emissions between 30-100MHz.

Mount the drive vertically on a solid, flat, non-flammable, vertical surface. It can be panel-mounted, or rail-mounted on a rail complying with EN50022 (35mm DIN).

DIN Mounting

To DIN mount the unit, hang the unit on the top DIN rail and push the unit onto the bottom DIN rail until it snaps in to position. Secure with a lower screw fixing. To release the unit, use a flat bladed screwdriver as shown.

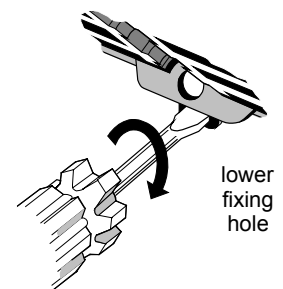

Ventilation

Maintain a minimum air clearance for ventilation of 100mm (4 inches) above and below the unit. When mounting two or more 650V units together, these clearances are additive. Ensure that the mounting surface is normally cool. Be aware that adjacent equipment may generate heat and also have clearance requirements. Provided the minimum clearance for ventilation is maintained, 650V drives may be mounted side-by-side.

3-2 Installing the Drive

Electrical Installation

IMPORTANT: Read the Safety Information on page Cont. 2 before proceeding.

Wiring Instructions

Local Control Wiring

This is the simplest installation. Every new drive will operate in Local Control when first powered-up. The keypad is used to start and stop the drive.

Refer to the Connection Diagram and install the:

- Thermistor cable, or link/jumper terminals TH1A and TH1B (we recommend you do use a thermistor)
- Motor cable
- Supply cable
- Follow the earthing/grounding and screening advice Refer to Chapter 4: "Operating the Drive"- Local Control Operation.

Minimum Connections

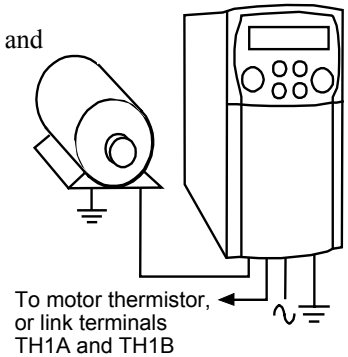

Remote Control Wiring

If operating in Remote Control you will use your control panel to start and stop the drive, via a speed potentiometer and switches or push-buttons.

Your wiring of the control terminals will be governed by the Application you use: refer to Chapter 12 for an explanation of the various Applications you can select and the appropriate control wiring. Application 1 is the default Application.

The diagram below shows the **minimum** connections to operate the drive for single-wire (switch) starting, and push-button starting. Other control connections for your Application are shown in Chapter 12 and can be made to suit your system.

Referring to the Connection Diagram:

- Follow the instructions for Local Control Wiring, as detailed above
- Install using minimum connections (suitable for Application 1 only), or refer to Chapter 12 and install the appropriate control wiring for your system

Minimum Connections for Application 1:

Single Wire Starting

Push-Button Starting

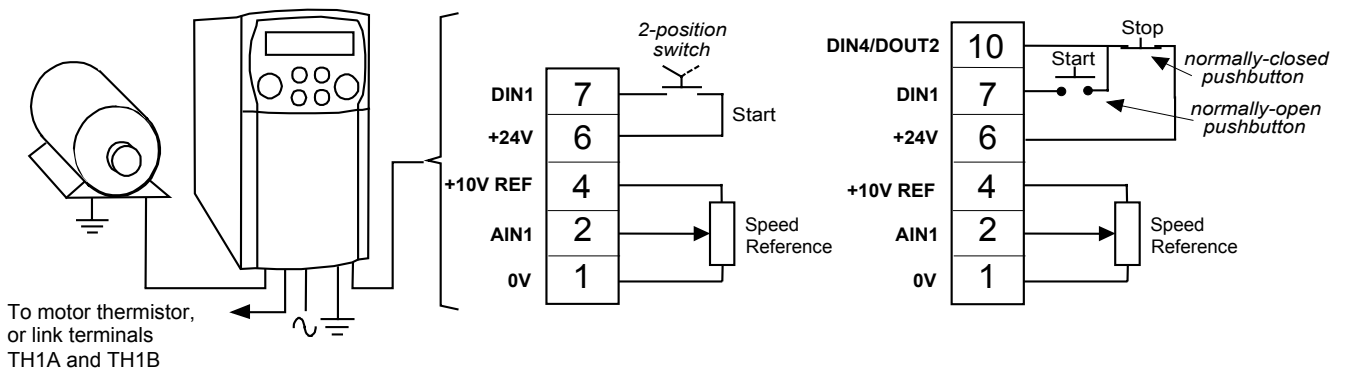

Note: You can still operate the drive in Local mode, if necessary, with any Application selected.

Refer to Chapter 4: "Operating the Drive" and follow the relevant instructions for Single Wire Starting or Push-Button Starting.

WARNING!

This product is designated as "professional equipment" as defined in EN61000-3-2. Where enforced, permission of the supply authority shall be obtained before connection to the low voltage domestic supply.

Ensure that all wiring is electrically isolated and cannot be made "live" unintentionally by other personnel.

The drive is suitable for use with both earth referenced supplies (TN) and non-earth referenced supplies (IT) when fitted with an internal ac supply EMC filter.

Connection Diagram

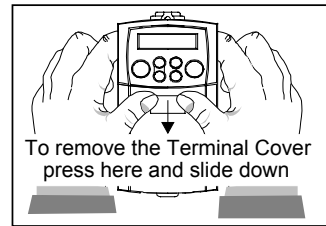
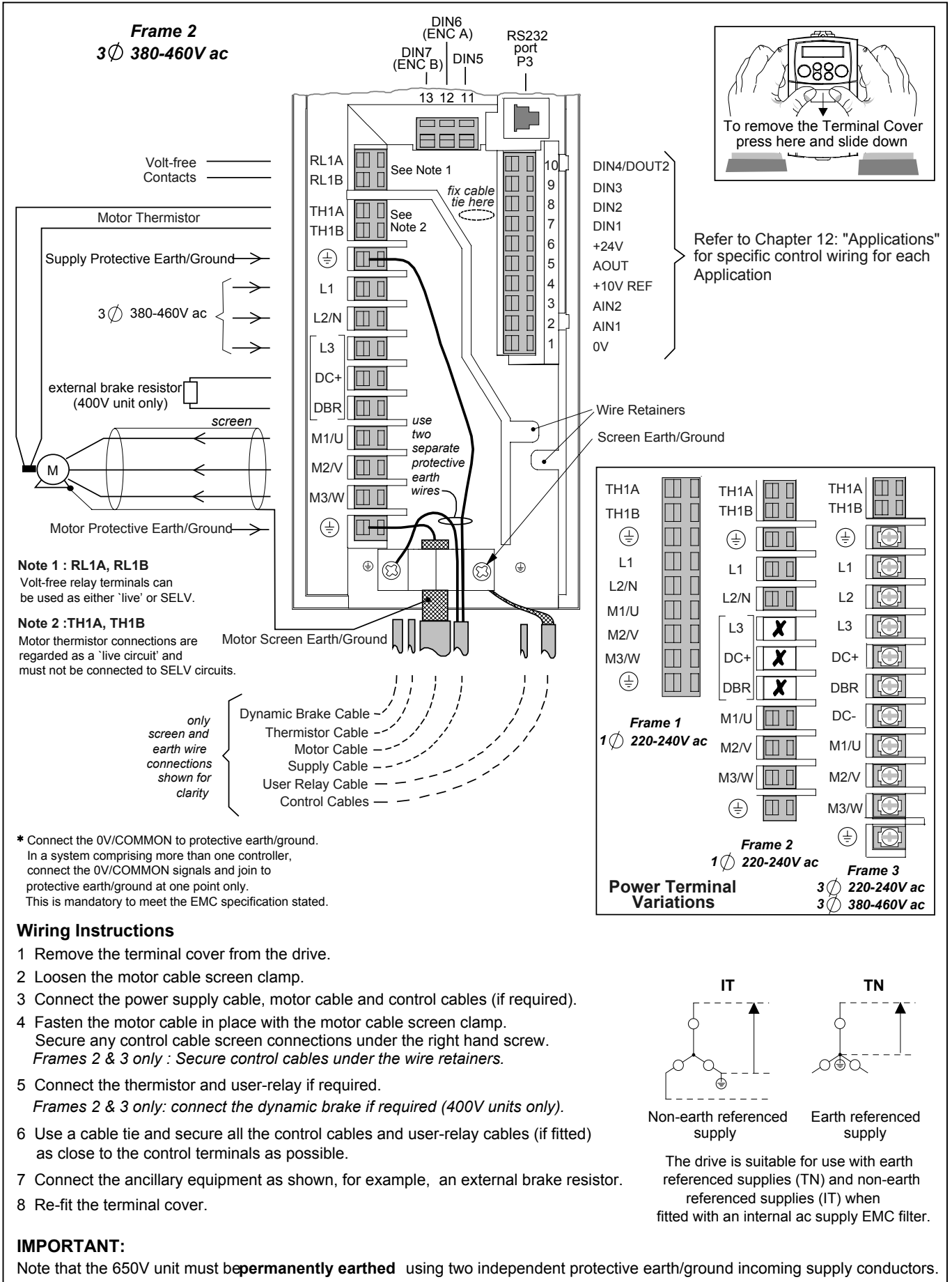

Refer to Chapter 12: "Applications" for specific control wiring for each Application



3-4 Installing the Drive

Control Wiring Connections

Terminal (SELV)	Name	Application 1 Default Function (for other Applications refer to Chapter 12: "Applications")	Range
P3	P3	RS232 port for use with remote-mounted RS232 keypad or programming PC	-
RL1A	User Relay	Volt-free contact	0-250Vac/24Vdc 4A
RL1B	User Relay	Volt-free contact	0-250Vac/24Vdc 4A
13	DIN7 (ENC B)	Run Reverse - configurable digital input 0V = forward, 24V = reverse	0-24V
12	DIN6 (ENC A)	Configurable digital input	0-24V
11	DIN5	Not Coast Stop - configurable digital input: 0V = Stop, 24V = Coast Stop	0-24V
10	DIN4/ DOU2	Configurable digital input/output Not Stop (input): 0V = No latching of Run (DIN1), 24V = Run latched	0-24V source open collector *
9	DIN3	Jog - configurable digital input: 0V = Stop, 24V = Jog	0-24V
8	DIN2	Direction - configurable digital input: 0V = Forward, 24V = Reverse	0-24V
7	DIN1	Run Forward - configurable digital input: 0V=Stop, 24V=Run	0-24V
6	+24V	24V supply for digital I/O	*
5	AOUT	Ramp Output - configurable analog output (10mA loading)	0-10V
4	10VREF	10V reference (10mA maximum loading)	10V
3	AIN2	Speed Trim - analog input 2	0-10V, 4-20mA
2	AIN1	Speed Setpoint - analog input 1	0-10V
1	0V	0V reference for analog/digital I/O	0V

* The total current available is 50mA, either individually or as the sum of terminal 6 & 10.

Power Wiring Connections

Terminal	Description	Function	Range	
			200V 1-Phase	200V/400V 3-Phase
TH1A	Thermistor	Connection to motor thermistor	It is good practice to protect motors by fitting temperature sensitive resistors. A typical resistance (up to a reference temperature of 125°C) is 200Ω, rising rapidly to 2000Ω above this temperature. Connect devices in series between TH1A and TH1B. Link the terminals if temperature sensors are not used.	
TH1B	Thermistor	Connection to motor thermistor		
	Reference Terminal	Supply protective earth (PE). This terminal must be connected to a protective (earth) ground for permanent earthing .		
L1 *	Power Input	Single and three phase live connection	220/240V ac ±10% rms with respect to L2/N. 50-60Hz (IT/TN)	220/240V or 380/460V ac ±10% rms with respect to L2, L3 phase-to-phase. 50-60Hz (IT/TN)
L2/N * L2	Power Input	Single phase neutral (or L2 three phase live connection)	220/240V ac ±10% with respect to L1. 50-60Hz (IT/TN)	220/240V or 380/460V ac ±10% with respect to L1, L3. 50-60Hz (IT/TN)
L3	Power Input	Three phase live connection	Not applicable	220/240V or 380/460V ac ±10% with respect to L1, L2. 50-60Hz (IT/TN)
DC-	<i>No user connection</i>			
DC+	Dynamic Brake	Connection to external brake resistor	Not applicable	Frame 2 (high volt only) & 3. See "Internal Dynamic Brake Switch" table
DBR	Dynamic Brake	Connection to external brake resistor	Not applicable	Frame 2 (high volt only) & 3. See "Internal Dynamic Brake Switch" table
M1/U M2/V M3/W	Motor Outputs	Connection for motor	Motor rated at: 0 to 220/240V ac 0 to 240Hz	Motor rated at: 0 to 220/240V or 0 to 380/460V ac 0 to 240Hz
	Reference Terminal	Supply protective earth (PE). This terminal must be connected to a protective (earth) ground for permanent earthing .		

Terminal Block Acceptance Sizes

Wire sizes should be chosen with respect to the operating conditions and your local National Electrical Safety Installation Requirements. Local wiring regulations always take precedence.

Frame Size	Power Terminals (maximum wire size)	Brake Terminals (maximum wire size)	Thermistor/Control Terminals (maximum wire size)
Frame 1 230V	2.5mm ² /12 AWG	Not Applicable	2.5mm ² /12 AWG
Frame 2 230V	2.5mm ² /12 AWG	Not Applicable	2.5mm ² /12 AWG
Frame 2 400V	2.5mm ² /12 AWG	2.5mm ² /12 AWG	2.5mm ² /12 AWG
Frame 3 230V	6.0mm ² /10 AWG	6.0mm ² /10 AWG	2.5mm ² /12 AWG
Frame 3 400V	6.0mm ² /10 AWG	6.0mm ² /10 AWG	2.5mm ² /12 AWG

Power Wiring

Note: For specified EMC emission and immunity performance, install to EMC Installation Instructions. Refer to Chapter 10: "Certification for the Drive" - for more information

Terminal tightening torque for Frame 3 power connections is 20 lb.in (2.26Nm).

Protect the incoming mains supply using the specified fuse, or RCD circuit breaker Type B.

IMPORTANT: We do not recommend the use of circuit breakers (e.g. RCD, ELCB, GFCI), however, where their use is mandatory, they must:

- Operate correctly with dc and ac protective earth currents (i.e. type B RCDs as in Amendment 2 of IEC755).
- Have adjustable trip amplitude and time characteristics to prevent nuisance tripping on switch-on.

Control Wiring

Control wiring of between 0.08mm² (28AWG) and 2.5mm² (12AWG) can be used. Ensure all wiring is rated for the highest system voltage. All control terminals are SELV, i.e. double-insulated from power circuits.

Using Cage Clamp Terminals

Strip wire insulation to 5-6mm (0.20-0.24 inches), or alternatively use wire-crimps. Use a flat-bladed screwdriver, maximum blade size 3.5mm. The cage provides the correct force for a secure connection.

IMPORTANT: DO NOT lever or turn the screwdriver.

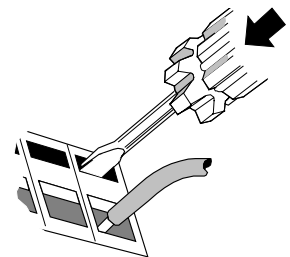

3-6 Installing the Drive

Optional Equipment

Fitting the Remote 6511 Keypad

You can remote-mount the drive-mounted Keypad using:

- the RS232 (P3) port located under the terminal cover
- A standard P3 lead, SSD Part Number CM057375U300, which is used to connect the Keypad to the drive.

Two self-tapping screws are provided with the Keypad. Remove the protective film from the gasket. An enclosure rating of IP54 is achieved for the remote Keypad when correctly mounted.

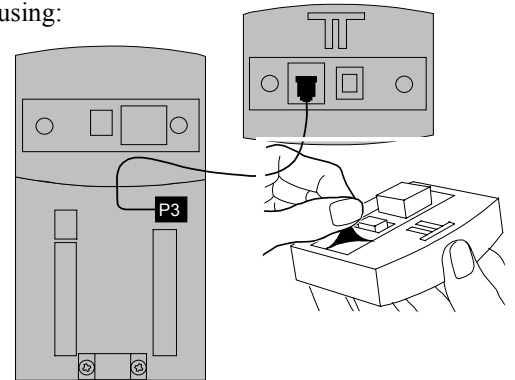

Assembly Procedure

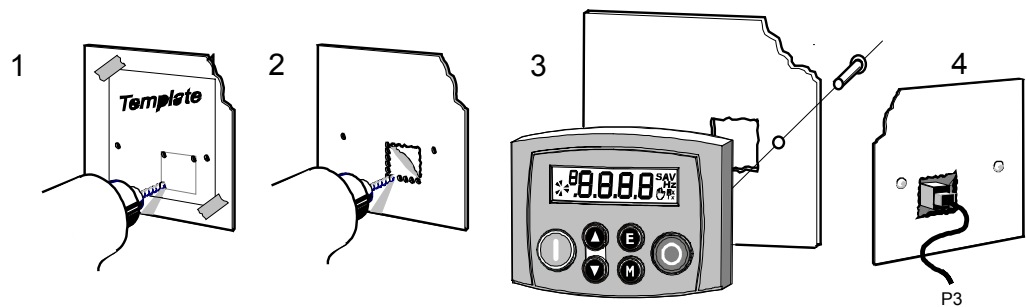

Cut-out Dimensions

The drawing below can be photocopied actual size (100%) and used as a template.

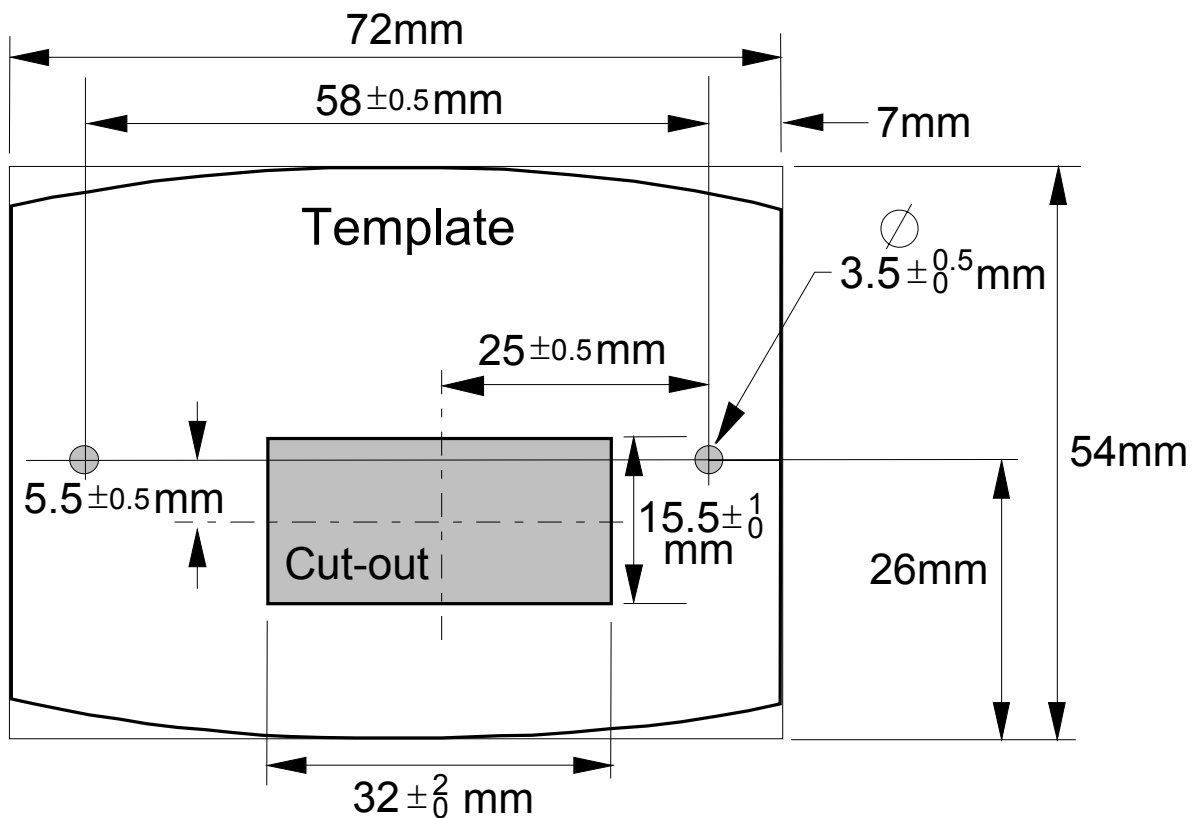



Fitting the Remote 6521/6901 Keypad

The 6052 Mounting Kit is required to remote-mount a 6521 Keypad. An enclosure rating of IP54 is achieved for the remote Keypad when correctly mounted using the 6052 Mounting Kit.

6052 Mounting Kit Parts for the Remote Keypad

Tools Required

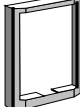
No. 2 Posidrive screwdriver.

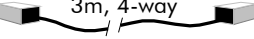
6052 Mounting Kit			
1		1	
4	 No. 6 x 12mm	1	 3m, 4-way

Assembly Procedure

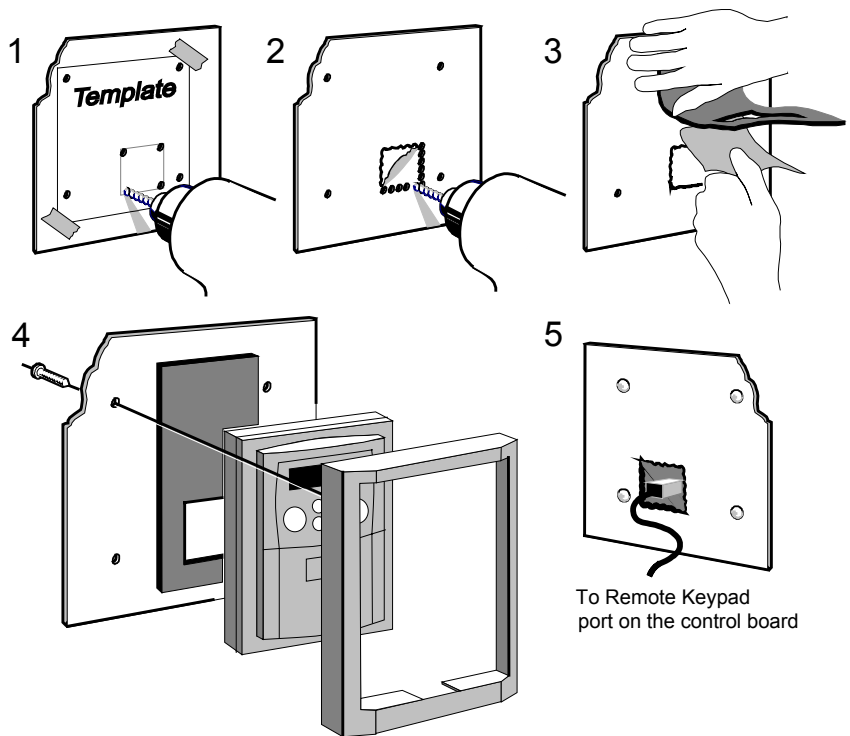

Cutout Dimensions

An actual size template is provided with the Keypad/6052 Mounting Kit.

Figure 3-1 Mounting Dimensions for the Remote-Mounted Keypad 6521/6901

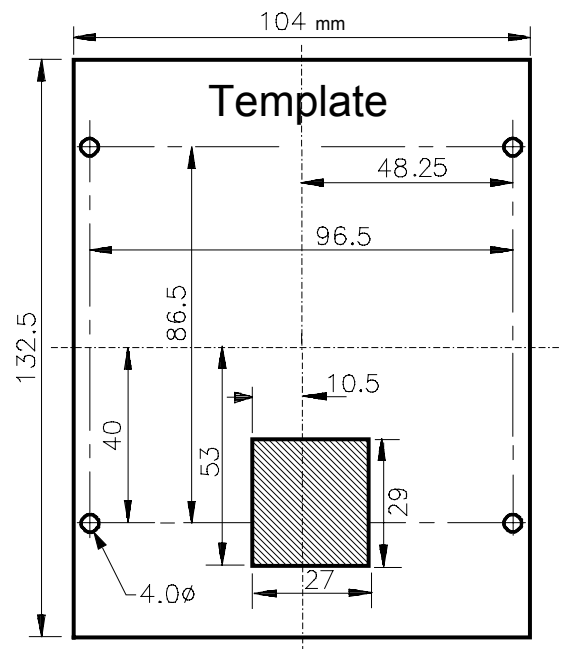
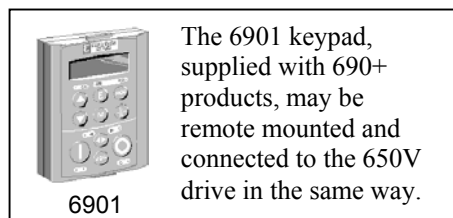

3-8 Installing the Drive

RS485/RS232 Communication Module

You can create a network of drives by linking a Master (PC/PLC) to one or more 650V drives fitted with this module.

Plug this Communication Module on to the front of the 650V drive, replacing the keypad.

It converts signals from the host 650V drive into RS485 or RS232, and vice versa, so that information can be shared between the Master and 650V drive(s).

Wiring is very simple - all connections are SELV (Safe Extra Low Voltage). Select to use RS485 or RS232 by wiring to the appropriate terminal on the module.

Note: RS485 and RS232 terminals cannot be used simultaneously.

We recommend you ground the module to the system earth using the Functional Earth terminal.

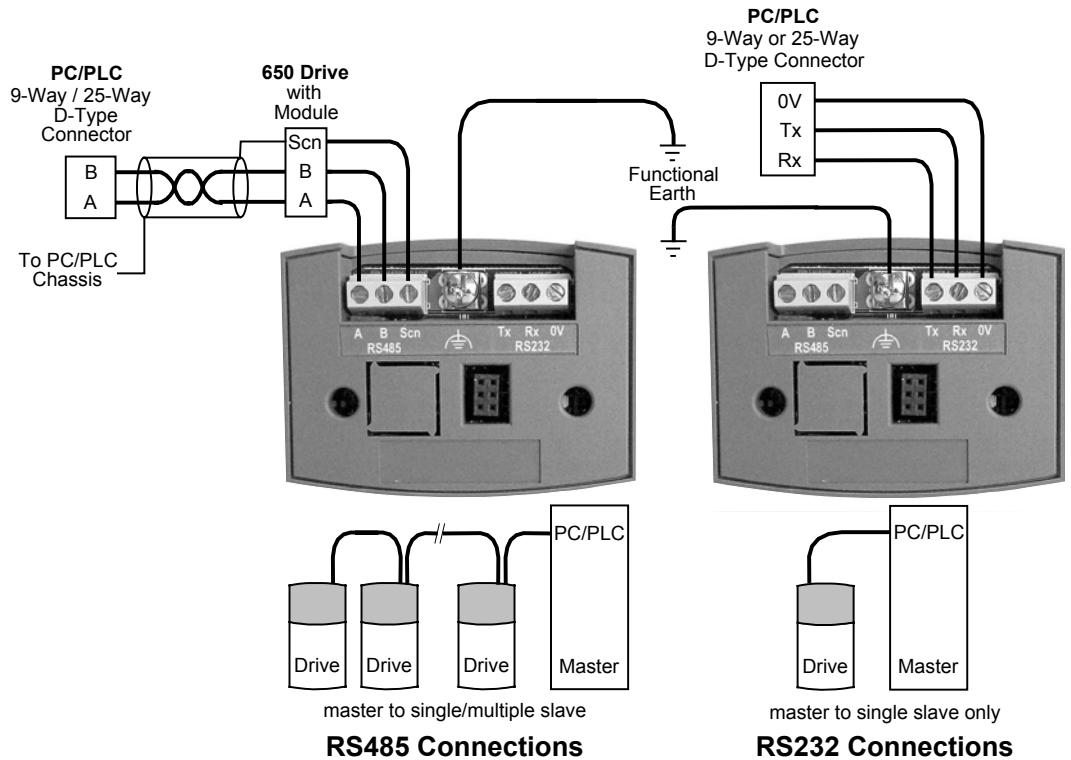

Wiring Specifications		
	RS485 Connections	RS232 Connections
Network Type	2-Wire Shielded Twisted-Pair	3-Wire Un-Shielded Cable
Connections	A=RxA/TxA, B=RxB/TxB, Shield	Rx, Tx, Ground (0V)
Signal Levels	To RS485 Standard	To RS232 Standard
Receiver Input Impedance	¼ Unit Load	3 kΩ minimum 7kΩ maximum
Maximum Cable Length	1200m (4000ft)	3 metres
Maximum Baud Rate	57.6kbaud	57.6kbaud
Maximum Number of Units	32 including slaves and masters	2: 1 master and 1 slave only

LED Indications

The module has three LEDs providing diagnostic information about the 650V host drive's 'Health', 'Receive' and 'Transmit' activity.

HEALTH = Green, Rx = Red, Tx =Red



LED Name	LED Duty	Drive State
HEALTH	SHORT FLASH	Re-configuration, or corrupted non-volatile memory at power-up
	EQUAL FLASH	Tripped
	ON	Healthy
	LONG FLASH	Braking
	OFF	No drive power, or serious hardware fault
Rx	INTERMITTENT	Indicates activity on the 'receive' line carrying data from the Master
Tx	INTERMITTENT	Indicates activity on the 'transmit' line carrying data to the Master

Configure the Drive

Before the module can be used you must configure the drive to your system. Set-up the parameters in the SERIAL menu as appropriate. Refer to Chapter 6: "Programming Your Application" - SET::SERL Menu, parameters ^SSE01 to ^SSE08.

For Tag number information refer to the 650V Software Product Manual, available on the SSD Drives website: www.SSDdrives.com.

Note: This Option can only be used on drives using software version 4.1 or higher.

Encoder Connections

The drive is **only** suitable for use with single-ended encoders. Take special care wiring the encoder to the drive due to the low level of the signals.

All wiring to the drive should be made in screened cable. Use cable with an overall screen and a screen over each individual pair. To ensure compliance with the EMC Directive the overall cable screen should be connected to the drive chassis.

Recommended cable (pairs individually screened):

Belden equivalent 8777

SSD Drives Part Number CM052666

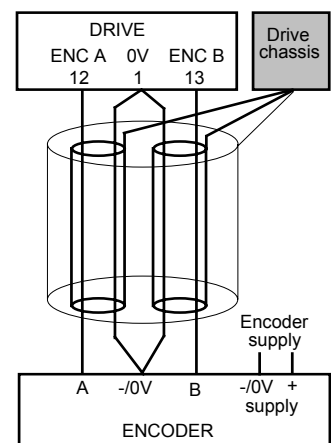

The drive will operate with 5-24V encoders. Provide the correct supply for the encoder. Do not use the 10V or 24V supply from the drive.

The maximum input frequency of terminals 12 and 13 (ENCA and ENCB) is 100kHz.

3-10 Installing the Drive

Line Choke

Cables are considered to be electrically sensitive, clean or noisy. A line choke is used to reduce harmonic emission to meet the limits of EN61000-3-2.

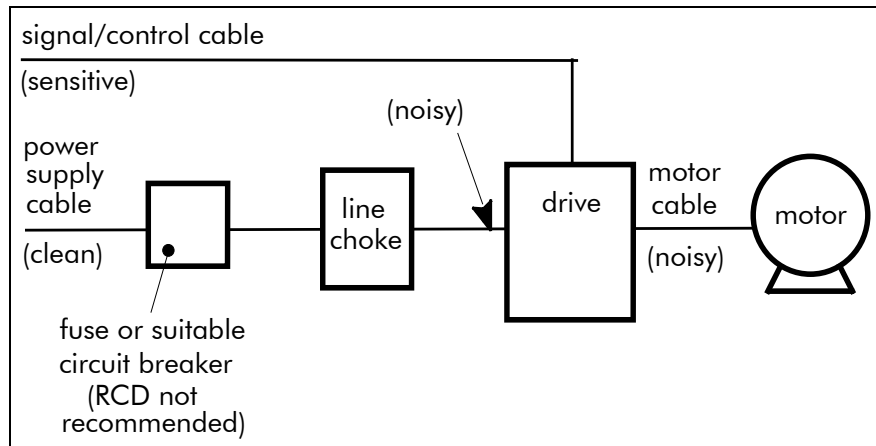

The choke is for use on the following drive:

Phase	Drive Nominal Input Voltage (V)	Drive Power (kW/hp)	Rated Current (A _{eff})	Rated Inductivity (mH)	Choke Part Number
3	400	0.37/0.5	6	4.88	CO467763U003 (Europe)

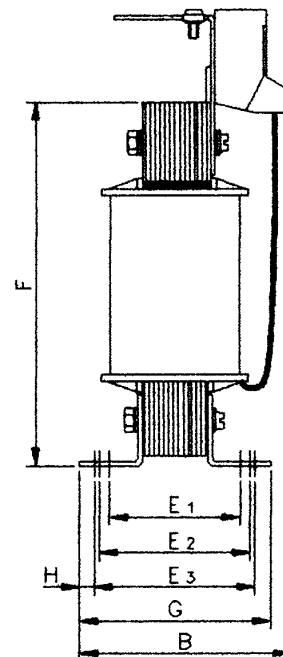
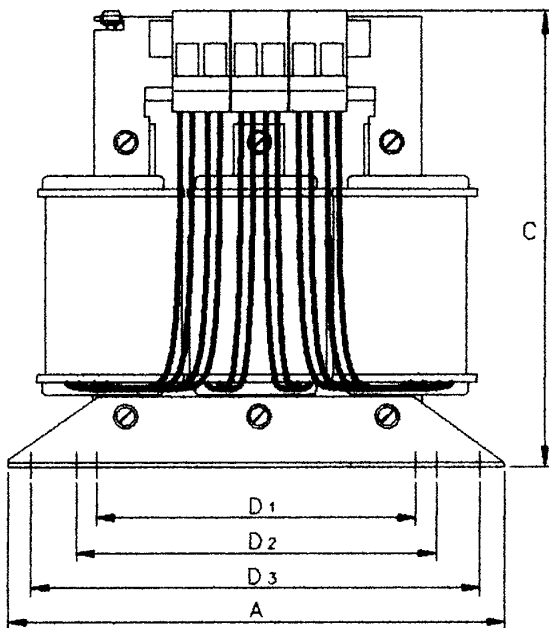

Rated Current (A _{eff})	Rated Inductivity (mH)	A (mm)	B (mm)	C (mm)	D1 (mm)	D2 (mm)	D3 (mm)	E1 (mm)	E2 (mm)	E3 (mm)	F*	G (mm)	Fixing Screws	Weight (kg/lbs)
650 Frame 2, 3-phase, 400V, 0.37kW/0.5Hp														
6	4.88	148	76	151	90	100	136	39	45	49	110	69	M4	2.1/4.63

* dimension is dependent of the air gap

OPERATING THE DRIVE

Pre-Operation Checks

WARNING!

Wait for 5 minutes after disconnecting power before working on any part of the system or removing the terminal cover from the drive.

Initial checks before applying power:

- Check for damage to equipment.
 - Mains power supply voltage is correct.
 - Motor is of correct voltage rating and is connected in either star or delta, as appropriate.
 - Check all external wiring circuits - power, control, motor and earth connections.
- Note:* Completely disconnect the drive before point to point checking with a buzzer, or when checking insulation with a Meggar.
- Check for loose ends, clippings, drilling swarf etc. lodged in the drive and system.
 - If possible check that the motor can be turned freely, and that any cooling fans are intact and free from obstruction.

Ensure the safety of the complete system before the drive is energised:

- Ensure that rotation of the motor in either direction will not cause damage.
- Ensure that nobody else is working on another part of the system which will be affected by powering up.
- Ensure that other equipment will not be adversely affected by powering up.

Prepare to energise the drive and system as follows:

- Remove the supply fuses, or isolate using the supply circuit breaker.
- Disconnect the load from the motor shaft, if possible.
- If any of the drives control terminals are not being used, check whether these unused terminals need to be tied high or low.
- If the motor thermistor terminals are not connected to a motor thermistor, connect these terminals together.
- Check external run contacts are open. Check external speed setpoints are all zero.

Re-apply power to the drive and system

Initial Start-up Routines

Note: Refer to Chapter 5: "Using the Keypad" to familiarise yourself with the keypad's indications, and how to use the keys and menu structure.



IMPORTANT

When power is applied to the drive in Remote Control, it will immediately start running if the RUN signal is active.

WARNING!

Unpredictable motion, especially if motor parameters are incorrect.
 Ensure no personnel are in the vicinity of the motor or any connected machinery.
 Ensure that machinery connected to the motor will not be damaged by unpredictable motion.
 Ensure that the emergency stop circuits function correctly before running the motor for the first time.

The drive can be started in either Remote Control or Local Control. **By default, the drive will start in Local Control.**

These routines assume that the drive's control terminals are wired as shown in the Control Wiring Connections in Chapter 3.

Connected in this way, a positive setpoint will rotate the motor in a clockwise direction when viewed down the shaft, looking toward the motor.

Note: If during the start-up routine the display shows either an alarm (indicated by the letter "A") or a flashing Warning message, refer to Chapter 7: "Trips and Fault Finding".



A typical alarm

4-2 Operating the Drive

Local Control Operation



This is the simplest method of operating the drive.

Connect the keypad to the drive and power-up the unit.

The drive will display the Local screen. If not, refer to Chapter 5 and select Local Control.

Follow the instructions opposite to start and stop the motor.

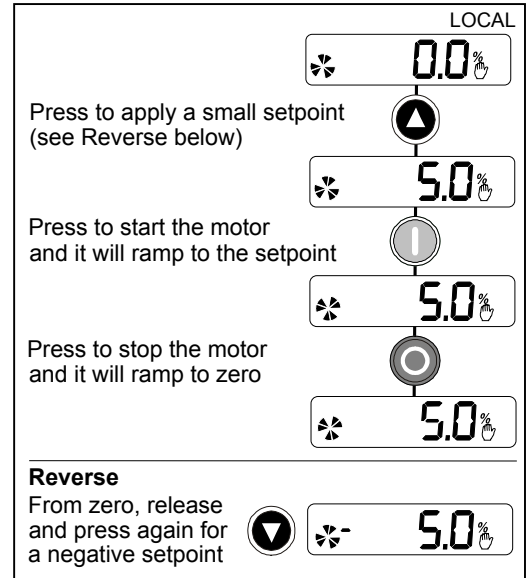

Remote Control Operation

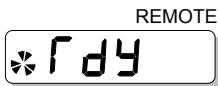

Connect the keypad to the drive and power-up the unit.

The drive will display the Local screen. Refer to Chapter 5 and select Remote Control.

IMPORTANT: Ensure that the speed potentiometer is set to zero.

Follow the instructions below to start and stop the motor using your control panel.

Reverse the motor's direction of rotation using the DIN2 connection (0V = forward, +24V = reverse). Alternatively, swap two of the motor phases (**WARNING: Disconnect the mains supply first**).

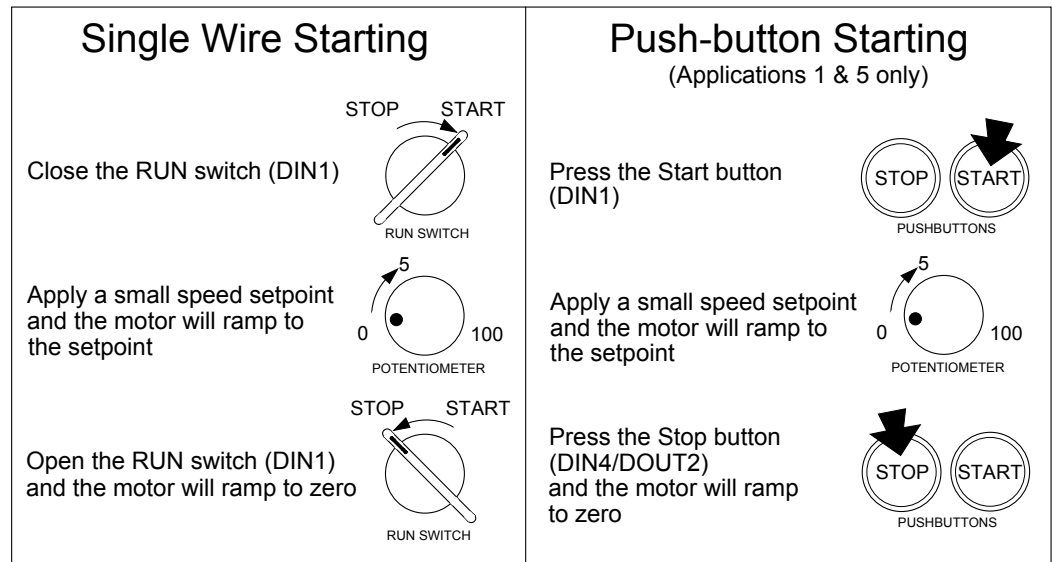

The installation of your drive is now complete:

The drive will operate as an open-loop drive. It is programmed to control an induction motor of equivalent power, current, and voltage rating to the drive. Using the keypad (or other suitable programming tool) the drive must now be set-up:

- as a simple Open-loop drive (V/F Mode)
provides less torque control at low speeds, but is ideal for controlling fans and pumps
- in Sensorless Vector Mode
used for maximum torque control at low speeds, for example, in operating a lift

Set-up as an Open-loop drive (V/F Mode)

The drive will run the motor without any further adjustment. However, the parameters below are pre-loaded with "typical" values that are dependent upon the Product Code for the drive. To improve performance you can enter "actual" values to suit your system; particularly P6 and P7 whose values should be found on the motor nameplate. Now refer to "Tuning the Drive to Your System", page 4-5.

Note: For Product Code dependent defaults, refer to Chapter 6: "Programming Your Application".

Display	Parameter	Default	Brief Description
5CL01	CONTROL MODE	VOLTS / HZ (0)	This parameter contains the main method of motor control used by the drive, and by default is set to VOLTS/HZ
P 6	MOTOR CURRENT	Default is Product Code dependent	Enter the motor nameplate full-load line current
P 7	BASE FREQUENCY	Default is Product Code dependent	Enter the output frequency from the motor nameplate
P 13	FIXED BOOST	Default is Product Code dependent	Enter a boost for starting torque to help with high friction loads

Set-up using the Sensorless Vector Mode

By default, the drive is operating in V/F Mode. Use the keypad to change to Sensorless Vector Mode:

Display	Parameter	Default	Brief Description
5CL01	CONTROL MODE	Set to SENSORLESS VEC (1)	This parameter contains the main method of motor control used by the drive, and by default is set to VOLTS/HZ

To operate in Sensorless Vector Mode, the drive needs to know more about your system. You **MUST** carry out an Autotune (described over the page) but first, enter "actual" values from your motor nameplate for the parameters listed below.

Note: For Product Code dependent defaults, refer to Chapter 6: "Programming Your Application".

Display	Parameter	Default	Brief Description
P 2	MAX SPEED	Default is Product Code dependent	Set the speed in Hz at which the 650V will run when the maximum setpoint is applied
P 6	MOTOR CURRENT	Default is Product Code dependent	Enter the motor nameplate full-load line current
P 7	BASE FREQUENCY	Default is Product Code dependent	Enter the output frequency from the motor nameplate
5CL02	NAMEPLATE RPM	1445.0	Enter the motor nameplate full-load rated speed. This is the motor speed in rpm at base frequency minus full load slip
5CL11	MOTOR POLES	4-pole	Enter the number of motor poles shown on the motor nameplate
5CL12	MOTOR VOLTAGE	Default is Product Code dependent	Enter the motor nameplate voltage at base frequency
5CL14	MAG CURRENT	Default is Product Code dependent	Enter the motor model no-load line current only if performing a Stationary Autotune (see over the page)

4-4 Operating the Drive

Autotuning the Drive

IMPORTANT: You **MUST** carry out an Autotune if you intend to use the drive in Sensorless Vector Mode. If you are using it in Volts/Hz control an Autotune is not necessary.

The Autotune procedure identifies some of the more obscure characteristics about your motor, and automatically loads them into the drive.

Follow the procedure below to complete the Autotune. When the Autotune is finished, refer to "Tuning the Drive to Your System", page 4-5.

1 Stationary or Rotating Autotune?

Will the motor spin freely during the Autotune, i.e. not connected to a load?

- If it can spin freely, use a Rotating Autotune (preferred)
- If it cannot spin freely, use a Stationary Autotune

	Action	Requirements
Rotating Autotune <i>Preferred method</i>	Spins the motor up to the maximum speed set by the user to identify all necessary motor characteristics	Motor must spin freely during Autotune
Stationary Autotune <i>Only used when the motor cannot spin freely during the Autotune feature</i>	Motor does not spin during Autotune. A limited set of motor characteristics are identified	You must enter the correct value of magnetising current Do not subsequently operate the drive above base speed

2 Performing the Autotune

5CL20	AUTOTUNE MODE	0	Select the Autotune operating mode
5CL21	AUTOTUNE ENABLE	0	Enables the Autotune feature. Refer to "The Autotune Feature" below.

Performing a Rotating Autotune

Check that the motor can rotate freely in the forward direction. Ensure also that the motor is unloaded. Ideally, the motor shaft should be disconnected. If the motor is connected to a gearbox this is ok, provided that there is nothing on the output of the gearbox which could load the motor.

1. Set MAX SPEED (^P 2) to the maximum speed at which you will operate the drive in normal operation. The Autotune will characterise the motor up to 30% above this speed. If you later wish to run faster than this, you will need to carry out another Autotune.
2. Set the AUTOTUNE MODE (^S CL20) parameter to ROTATING (1).
3. Set AUTOTUNE ENABLE (^S CL21) to 1 (TRUE), and start the drive. The drive will carry out a Rotating Autotune, indicated by the Run and Stop led's flashing on the blank cover when fitted, or by flashing **Alt N** on the keypad. This may take several minutes, during which the motor will be accelerated to maximum speed and then brought to a stop. When complete, the drive is returned to the stopped condition and the AUTOTUNE ENABLE parameter is reset to 0 (FALSE).

Performing a Stationary Autotune

Before starting the stationary Autotune, you **MUST** enter the value of magnetising current for the motor (^S CL14). This may be available on the motor nameplate. If not, you may need to contact the motor supplier.

1. Set the AUTOTUNE MODE (^S CL20) parameter to STATIONARY (0).
2. Set AUTOTUNE ENABLE (^S CL21) to 1 (TRUE), and start the drive. The drive will carry out a Stationary Autotune, injecting current into the motor but not turning the shaft. The Run and Stop led's will flash on the blank cover when fitted, or **Alt N** will flash on the keypad. When complete, the drive is returned to the stopped condition and the AUTOTUNE ENABLE parameter is reset to 0 (FALSE).

Tuning the Drive to Your System

Finally, adjust the parameters below as necessary to tune the drive to your system. Refer to Chapter 6: "Programming Your Application" for details.

Display	Parameter	Default	Brief Description
P 2	MAX SPEED	Default is Product Code dependent	Set the speed in Hz at which the 650V will run when the maximum setpoint is applied. Sensorless Vector Mode: If you change this parameter when in this mode, you must carry out another Autotune.
P 3	MIN SPEED	0.0%	Set the minimum frequency at which the 650V will run, as a % of MAX SPEED
P 4	ACCEL TIME	10.0 s	Set the time taken for the 650V to ramp up from zero to MAX SPEED
P 5	DECEL TIME	10.0 s	Set the time taken for the 650V to ramp down from MAX SPEED to zero
P 8	JOG SETPOINT	10.0 %	Set the jogging speed setpoint, as a % of MAX SPEED
P 9	RUN STOP MODE	0	Select the method by which the motor speed is reduced to zero
P 11	V/F SHAPE	LINEAR	Select LINEAR or FAN flux characteristics (constant or quadratic respectively) when operating in V/F Mode
P 12	HEAVY/NORMAL DUTY	0	Refer to Chapter 6 : P12 for explanation, and consequence of changing P11
P 13	FIXED BOOST	Default is Product Code dependent	Set a boost for starting torque to help with high friction loads

THE KEYPAD

The 6511 Keypad (Man-Machine Interface, MMI) provides for local control of the drive, monitoring, and complete access for application programming.

The 650V can be fitted with either a Standard or Remote Keypad. Both Keypads fit on the front of the drive, but the Remote Keypad (with its extra connector) can also be remote-mounted up to 3 metres away using a connecting lead: refer to Chapter 3: “Installing the Drive” – Fitting the Remote Keypad.

To remove a Keypad, simply pull it away from the drive. To refit it, push it back into place.

The product rating label identifies the Drive/Keypad type: refer to Chapter 9: “Technical Specifications” – Understanding the Product Code.

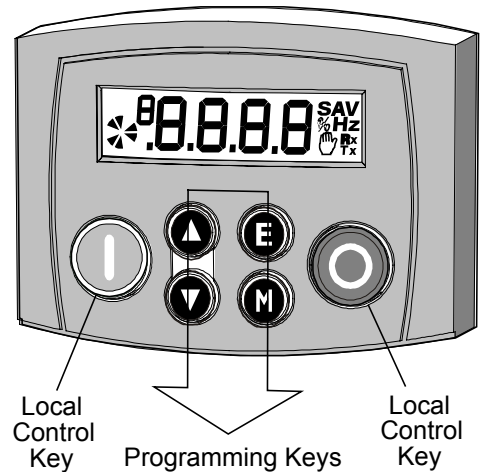

The Power-Up Condition

On initial power-up, direct from the factory, the drive is in Local Control and the MMI will display the Local Setpoint, **0.0** Hz.

All parameters will be at factory default settings. Any changes to these conditions are automatically saved. The drive will initialise on subsequent power-ups with the previously saved settings and control mode, Local or Remote Control.

Controlling the Drive using the Keypad

Control Key Definitions

Key	Operation	Description
	Escape	<i>Navigation</i> – Displays the previous level’s menu <i>Parameter</i> – Returns to the parameter list <i>Trip Display</i> – Removes Trip or Error message from display allowing investigation of parameters
	Menu	<i>Navigation</i> – Displays the next menu level, or the first parameter of the current Menu <i>Parameter</i> – Moves cursor to the left when the parameter is adjustable
	Increment	<i>Navigation</i> – Move upwards through the menu system <i>Parameter</i> – Increase value of the displayed parameter <i>Local Mode</i> – Increase value of the local setpoint
	Decrement	<i>Navigation</i> – Move down through the menu system <i>Parameter</i> – Decrease value of the displayed parameter <i>Local Mode</i> – Decrease value of the local setpoint
	Run	<i>Local Mode</i> – Run the drive <i>Trip Reset</i> – Resets trip condition allowing drive to resume operation
	Stop	<i>Local Mode</i> – Stops the drive. Trip Reset in all modes <i>Navigation</i> – Press and hold to toggle between Local and Remote Control modes (refer to page 5.4) <i>Trip Reset</i> – Resets trip condition allowing drive to resume operation

Display Indications

<p>P when in the Parameter menu S when in the Setup menu A when displaying an Alarm code - a negative parameter value</p>	<p>Displays the units for the value: S for time in seconds, A for current in Amps V for voltage in Volts, % for percentage Hz for frequency in Hertz</p>
---	--

Indicates the Control Mode

Represents a rotating shaft:
 clockwise = drive running forward
 anticlockwise = drive running in reverse

Indicates parameter numbers or values, trip information, error codes etc. See "Drive Status Indications" below.

Indicates the drive is in Local control. Drive is in remote control when not visible.

Indicates control via fieldbus communications

Drive Status Indications

The keypad can display the following status information:

Display	Status Indication and Meaning	Possible Cause
rdy	READY/HEALTHY No alarms present. Remote mode selected	
PASS	PASSWORD Current password must be entered before this parameter may be altered.	Enter password to change the parameter. Refer to page 5.5
LOC	LOCAL Local Control selected, healthy, no alarms present	Added or removed from the display letter-by-letter to indicate entering or leaving Local Control Jog (6901 op station only) or Run pressed while Coast Stop or Prog Stop lines are active, (low), on the sequencing block. Local control only.
STOP	STOP Coast Stop or Prog Stop active	
RUN	RUN Not possible to change between Local/Remote mode	The drive is running in Local mode or the Remote run signal is active
JOG	JOG Not possible to change between Local/Remote mode	The Remote jog signal is active
ENBL	ENABLE Pressed RUN or JOG key in Local mode while Enable signal is low	The drive Enable signal is inactive, (low)

The DIAGNOSTICS Menu

Display	Name	Description
00 Hz	FREQUENCY	The current output frequency in Hertz
00%	SPEED SETPOINT	The set point as a percentage of MAX SPEED
00 V	DC LINK VOLTS	$V_{ac} (rms) \times \sqrt{2} =$ dc link Volts (when motor stopped)
00 A	MOTOR CURRENT	The current load value in Amps

5-3 The Keypad



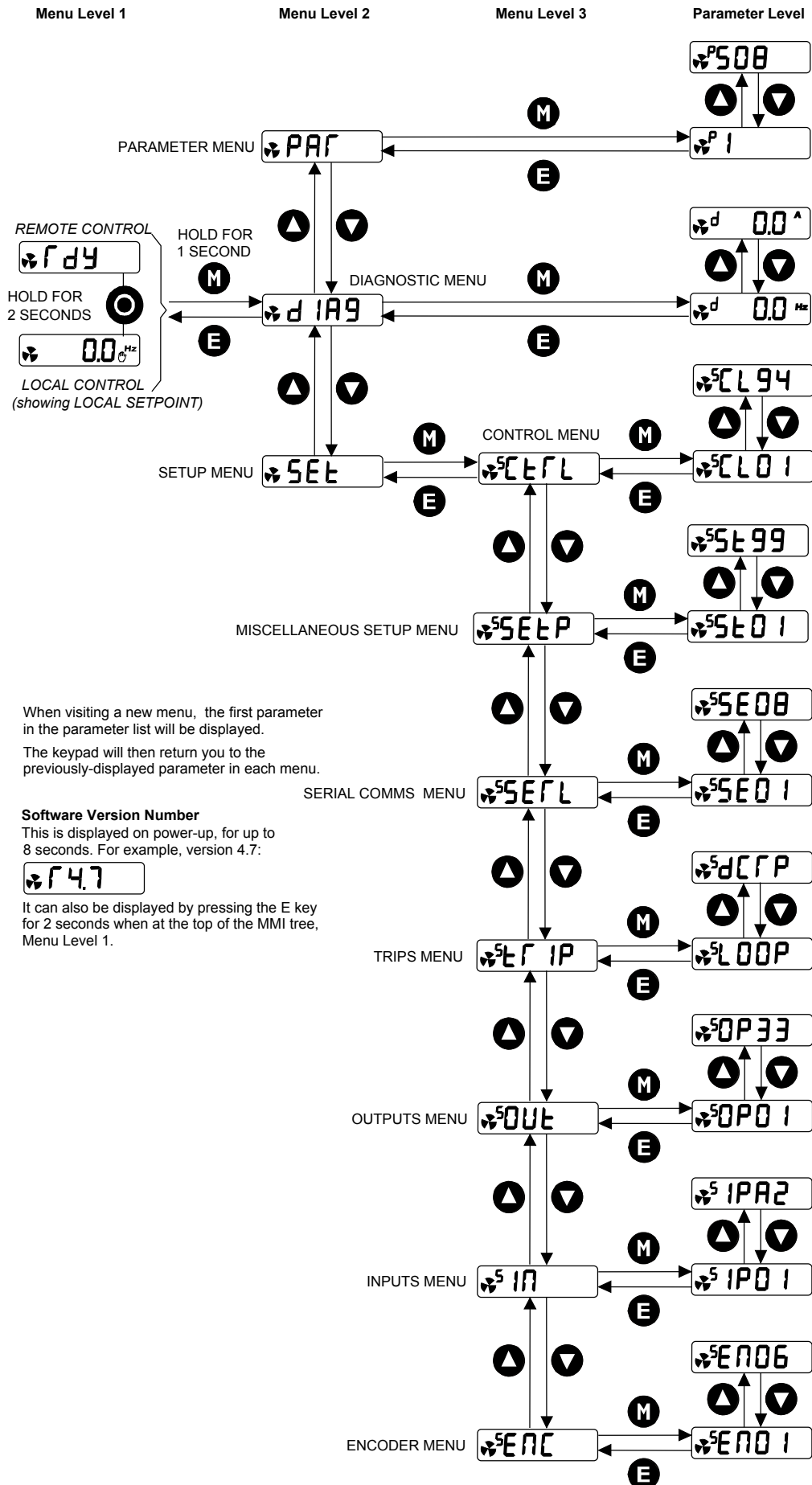

The Menu System

The menu system is divided into a “tree” structure with 3 menu levels.



How To Change a Parameter Value

You can change the values of parameters stored in the **PRF** and **SEt** menus. Refer to Chapter 6: “Programming Your Application” – Configurable Parameters for further information.

- View the parameter to be edited and press  to display the parameter’s value.
- Select the digit to be changed (pressing the  key moves the cursor from right to left).
- Use the   keys to adjust the value. Hold the key momentarily to adjust the value marginally, or hold the key to make rapid changes; the rate of change varies with the time held.
- Press  to return to the parameter display. The new value is stored.

Special Menu Features

Resetting to Factory Defaults (2-button reset)

Power-up the drive whilst holding the keys as shown to return to factory default settings.

This loads Application 1. Then press the  key.

Hold down the keys opposite:
Power-up the drive, continue to hold for at least 1 second

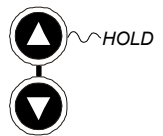





Changing the Drive Operating Frequency

Power-up the drive whilst holding the keys as shown to display the Engineers Menu.

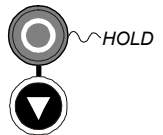
IMPORTANT: This menu contains sensitive parameters that can dramatically alter the running of the drive.

Hold down the keys opposite:
Power-up the drive, continue to hold for at least 1 second



This displays parameter ^E0.01. Press the  key to navigate to ^E0.02. Press the  key to edit the parameter: 0 = 50Hz (default), 1 = 60Hz. Select the required frequency then press the  key.

Power-down the drive. No permanent change has been made to the drive at this point. To save the change to parameter ^E0.02, you must now perform a 2-button reset (as above). Please note that this will return the drive to its factory default settings for the selected default frequency.

Selecting Local or Remote Control

The drive can operate in one of two ways:

- Remote Control:** Allowing access for application programming using digital and analog inputs and outputs
- Local Control:** Providing local control and monitoring of the drive using the Keypad

Local control keys are inactive when Remote Control is selected.

In Remote Control, the drive uses a remote setpoint. In Local Control, it uses the Local Setpoint parameter whose value is adjusted on the MMI.

Note: You can only change between Local and Remote Control when the drive is “stopped”, and either **r dY** or the Local Setpoint is displayed.

Remote to Local Control:

Hold this key down until the display shows **r dY**



Hold this key down until the display spells **L 0C**

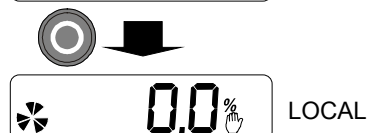

Release the key to display the Local Setpoint

5-5 The Keypad

Local to Remote Control:

View the Local Setpoint



Hold this key down until **LOC** is removed from the display



Release the key to display



Note: For safety reasons, the drive will not return to Remote Control if this will cause the drive to start. Check RUN and JOG inputs are low.

Password Protection

When activated, an odd-numbered password prevents unauthorised parameter modification by making all parameters read-only. The local setpoint is not made read-only if an even-numbered password is used. Password protection is set-up using the **P 99** parameter

Steps	ACTIVATE		TEMPORARY DE-ACTIVATION		REMOVE PASSWORD	
	Actions	Display	Actions	Display	Actions	Display
1	Go to P 99 Press M	0000	Try to edit any parameter with password activated	PASS → 0000	Go to P 99 Press M	PASS → 0000
2	Enter new password using ▲ ▼ for example	000 1	Enter current password using ▲ ▼ for example	000 1	Enter current password using ▲ ▼ for example	000 1
3	Press E repeatedly until top of menu is reached	r dy, Remote Setpoint or Local Setpoint	Press E	Original parameter displayed, password de-activated	Press E Reset to 0000 using ▲ ▼	0000
4	Press E to activate password Default = 0000, de-activated Any other value is a password	r dy, Remote Setpoint or Local Setpoint	A drive will power-up with the last password status. Temporary de-activation is lost on power-down.		Press E to remove password	P 99

Quick Application Selection

You can navigate immediately to the APPLICATION parameter, **P 1**, from power-up, as shown opposite.

Hold down the key opposite: HOLD
Power-up the drive, continue to hold for at least 1 second

Then, press the **M** key to display the current Application. Press again to allow the parameter to be changed.

Use the **▲** **▼** keys to select the appropriate Application by number.

Press the **E** key to load the Application.
Refer to Chapter 12: "Applications" for further information.

Selecting the Menu Detail

For ease of operation the drive can display full or reduced menus. Refer to Chapter 6 to see how the setting changes the displayed menu. Additional parameters are indicated with **F** in the table.

Navigate to the **St 99** parameter (SET::SETP::ST99) and press the **M** key. This toggles full or partial menu detail. The default setting of 0 provides partial menu detail. Set the parameter to 1 for full menu detail.

PROGRAMMING YOUR APPLICATION

You can program the drive to your specific application. This programming simply involves changing parameter values. For instance, parameter ^P1 selects various Applications which can be used as starting points for application-specific programming.

Each Application internally re-wires the drive for a different use when it is loaded. The default for the parameter is "1". Changing this parameter's setting to "2" will load Application 2. Refer to Chapter 12: "Applications" for further information.

If necessary, there are three parameters for tuning your drive. Refer to PID - Tuning Your Drive, page 6-13.

Saving Your Modifications

When parameter values are modified or an Application is loaded, the new settings are saved automatically. The drive will retain the new settings during power-down.

MMI Parameters

This table provides information about each parameter accessible using the keypad, or MMI (Man Machine Interface). For more information about these and additional parameters accessible using ConfigEd Lite (or other suitable programming tool), refer to the 650V Software Product Manual on our website: www.SSDdrives.com.

Key to MMI Parameters Table

F	Parameters indicated with F are visible with full menus only. Refer to the DETAILED MENUS parameter (ST 99).
M	Parameters indicated with M are Motor Parameters. They are not reset by changing Application using parameter ^P 1; all other parameters are reset to default values.
VF	Parameters indicated with VF are only visible when the drive is in VF (Volts/Hz) motor control mode, as selected by parameter ^S CL01.
SV	Parameters indicated with SV are only visible when the drive is in SV (Sensorless Vector) motor control mode, as selected by parameter ^S CL01.

Note: The "Range" for a parameter value is given in the Configurable Parameters Table. Ranges for outputs are given as "—.xx %", for example, indicating an indeterminate integer for the value, to two decimal places.

MMI Parameters Table

MMI Parameters Table				
Display	Parameter	Description	Range	Default
SET::PAR Menu				
P	APPLICATION	This parameter selects and loads the Application to be used. APP 0 will not control a motor. APP 6, 7 & 8 are for future use. You can edit an Application in ConfigEd Lite and, then set this parameter to CUSTOM to produce your own custom Application. Refer to the 650V Software Product Manual, Chapter 5: "Applications" which gives detailed information about each Application. Note: Parameter values are changed to factory settings by loading a new Application, except Motor Parameters (indicated M)	0= NULL 1= STANDARD 2= LOCAL/REM (AUTO/MANUAL) 3= PRESETS 4= RAISE/LOWER 5= PID 6= APP 6 7= APP 7 8= APP 8 9= CUSTOM	1

6-2 Programming Your Application

MMI Parameters Table				
Display	Parameter	Description	Range	Default
P 2	MAX SPEED M	The frequency at which the 650V will run when maximum setpoint is applied. The default is Product Code dependent	7.5 to 300Hz	50 or 60Hz
P 3	MIN SPEED	The minimum frequency at which the 650V will run, as a percentage of the MAX SPEED parameter	-100.0 to 100.0%	0.0%
P 4	ACCEL TIME	The time taken for the 650V output frequency to ramp up from zero to MAX SPEED	0.0 to 3000.0s	10.0s
P 5	DECEL TIME	The time taken for the 650V output frequency to ramp down from MAX SPEED to zero	0.0 to 3000.0s	10.0s
P 6	MOTOR CURRENT M	This parameter contains the motor nameplate full-load line current	0.01 to 999.99A	product code dependent
P 7	BASE FREQUENCY M	The output frequency at which maximum voltage is reached. The default is Product Code dependent	7.5 to 240Hz	50 or 60Hz
P 8	JOG SETPOINT	Speed the 650V will run at if the Jog input is high, as a percentage of the MAX SPEED parameter	-100.0 to 100.0%	10.0%
P 9	RUN STOP MODE	RAMPED : The motor speed is reduced to zero at a rate set by DECEL TIME (P5). A 2 second DC pulse is applied at end of ramp COAST : The motor is allowed to freewheel to a standstill DC INJECTION : On a stop command, the motor volts are rapidly reduced at constant frequency to deflux the motor. A low frequency braking current is then applied until the motor speed is almost zero. This is followed by a timed DC pulse to hold the motor shaft.	0=RAMPED 1=COAST 2=DC INJECTION	0
P 11	V/F SHAPE	LINEAR LAW: This gives a constant flux characteristic up to the BASE FREQUENCY FAN LAW: This gives a quadratic flux characteristic up to the BASE FREQUENCY. This matches the load requirement for fan and most pump applications Refer to P12	0=LINEAR LAW 1=FAN LAW	0

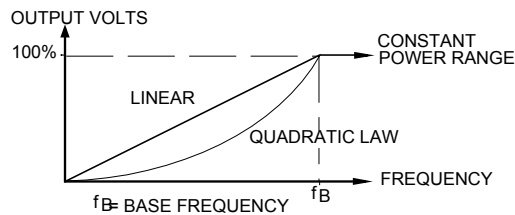

MMI Parameters Table

Display	Parameter	Description	Range	Default
P 12	NORMAL DUTY	<p>% OF RATED MOTOR CURRENT</p> <p>150% 127.5% 105% 100%</p> <p>100% overload for 30s (Heavy Duty)</p> <p>30 60</p> <p>TIME (s)</p> <p>FALSE - HEAVY DUTY: Inverse time allows 150% overload for 30s, then ramps back the current limit to 105% over a 10s period. At a lower load, the overload area remains the same, e.g. at 127.5% load for 60s - after 60s has expired, the output of the inverse time function is ramped back over a 10s period from 150% as before.</p> <p>TRUE - NORMAL DUTY: current limit is set to 110% motor current, inverse time delay is set to 30s</p> <p>When P11 is changed from FAN LAW to LINEAR LAW, P12 is set to 0 (HEAVY DUTY)</p> <p>When P11 is changed from LINEAR LAW to FAN LAW, P12 is set to 1 (NORMAL DUTY)</p> <p>P12 can be changed independently</p> <div style="border: 1px solid black; padding: 5px; margin-top: 10px;"> <p><i>NORMAL DUTY was previously referred to as Quadratic Torque in past Eurotherm Drives' manuals.</i></p> </div>	0=FALSE 1=TRUE	0
P 13	FIXED BOOST MVF	<p>Used to correctly flux the motor at low speeds. This allows the drive to produce greater starting torque for high friction loads. It increases the motor volts above the selected V/F characteristic at the lower end of the speed range</p> <p>OUTPUT VOLTS</p> <p>100% 25% 0%</p> <p>INCREASED TORQUE FLUXING</p> <p>NORMAL FLUXING</p> <p>INCREASING BOOST</p> <p>f_B = BASE FREQUENCY</p> <p>CONSTANT POWER RANGE</p> <p>f_B FREQUENCY</p>	0.00 to 25.00%	product code dependent
P 99	PASSWORD	A password may be set to prohibit unauthorised adjustment of parameters. When P99 is set to non-zero you will be required to match this value before parameters can be adjusted	0000 – FFFF	0000
Parameters P301 to P308 are visible in the PAR menu when Application 3 is selected in parameter P1				
P 301	PRESET 0	A user-adjustable speed preset, set by potentiometer	-100.00 to 100.00	-
P 302	PRESET 1	A user-adjustable speed preset	-100.00 to 100.00	20.00
P 303	PRESET 2	A user-adjustable speed preset	-100.00 to 100.00	50.00
P 304	PRESET 3	A user-adjustable speed preset	-100.00 to 100.00	100.00
P 305	PRESET 4	A user-adjustable speed preset	-100.00 to 100.00	-10.00
P 306	PRESET 5	A user-adjustable speed preset	-100.00 to 100.00	-20.00
P 307	PRESET 6	A user-adjustable speed preset	-100.00 to 100.00	-50.00
P 308	PRESET 7	A user-adjustable speed preset	-100.00 to 100.00	-100.00
Parameters P401 to P404 are visible in the PAR menu when Application 4 is selected in parameter P1				
P 401	R/L RAMP TIME	The time taken to ramp the Raise/Lower output from 0.00% to 100.00% of its value	0.0 to 600.0s	10.0s
P 402	R/L MAX VALUE	The maximum value for the ramp output	-100.00 to 100.00%	100.00%
P 403	R/L MIN VALUE	The minimum value for the ramp output	-100.00 to 100.00%	0.00%
P 404	R/L RESET VALUE	The value the output is set to when Reset is TRUE, when DIN4 (terminal 10) is 24V in Application 4	-100.00 to 100.00%	0.00%

6-4 Programming Your Application

MMI Parameters Table				
Display	Parameter	Description	Range	Default
<i>Parameters ^P501 and ^P506 are visible in the PAR menu when Application 5 is selected in parameter ^P1</i>				
P 501	PI P GAIN	The PI proportional gain	0.00 to 100.00	0.10
P 502	PI I GAIN	The PI integral gain	0.00 to 100.00	1.00
P 503	PID D GAIN	The PID derivative gain	0.00 to 100.00	0.00
P 504	PID D FILTER TC	In order to help attenuate high frequency noise on the derivative term, a first order lag has been provided. This parameter determines the filter time constant.	0.05 to 10.00s	0.05s
P 505	PID FEEDBACK GAIN	A multiplier applied to the feedback signal of the PID	-10.00 to 10.00	1.00
P 506	PID LIMIT	Determines the maximum positive and negative excursion (Limit) of the PID output	0.00 to 300.00%	300.00%
P 507	PID SCALING	This parameter represents an overall scaling factor which is applied after the PID positive and negative limit clamps	-3.0000 to 3.0000	1.0000
P 508	PID ERROR	The result of SETPOINT - FEEDBACK x FEEDBACK GAIN	—.xx %	—.xx%
P 509	PID OUTPUT	The output of the PID function block	—.xx %	—.xx %
<i>Parameters ^P901 and ^P908 are visible in the PAR menu when there are corresponding entries in the CUSTOM MENU block.</i>				
P 901	CUSTOM 1	Select a parameter to be displayed in the PAR Menu by entering the Tag Number for the parameter using ConfigEd Lite (or other suitable programming tool). Eight parameters can be entered into the menu. CUSTOM 1 is the first of the new parameters in the menu, CUSTOM 2 is the second of the new parameters in the menu, and so on. These parameters contained in P901 to P908 will appear at the bottom of the parameter list for the PAR Menu. Enter 0 to leave a position in the menu unused.	0 to 1655	0
P 902	CUSTOM 2	As ^P 901	0 to 1655	0
P 903	CUSTOM 3	As ^P 901	0 to 1655	0
P 904	CUSTOM 4	As ^P 901	0 to 1655	0
P 905	CUSTOM 5	As ^P 901	0 to 1655	0
P 906	CUSTOM 6	As ^P 901	0 to 1655	0
P 907	CUSTOM 7	As ^P 901	0 to 1655	0
P 908	CUSTOM 8	As ^P 901	0 to 1655	0

SET::CTRL Menu				
5CL01	CONTROL MODE	This parameter contains the main method of motor control used by the drive	0=VOLTS/HZ 1=SENSORLESS VEC	0
5CL02	NAMEPLATE RPM	This parameter contains the motor nameplate full-load rated speed. This is the motor speed in rpm at base frequency minus full load slip	0.1 to 30000.0 RPM	product code dependent
5CL03	FLY-CATCH ENABLE	Enables flycatching in Volts/Hz control mode when TRUE. Allows the drive to catch a spinning load.	0=FALSE 1=TRUE	0
5CL03	FLY-CATCH ENABLE	Enables flycatching in Sensorless Vector control mode when TRUE. Allows the drive to catch a spinning load.	0=FALSE 1=TRUE	0

MMI Parameters Table				
Display	Parameter	Description	Range	Default
5CL04	SLIP COMP ENABLE VF	Slip compensation is operational when TRUE. Eliminates motor speed variations under load conditions in V/F Fluxing Mode when the correct value for MAG CURRENT is entered into ⁵ CL14	0=FALSE 1=TRUE	0
5CL05	STABILISATION ENABLE VF	Enables the stabilisation function when TRUE. Eliminates light load speed variations in V/F Fluxing Mode	0=FALSE 1=TRUE	1
5CL06	VOLTAGE CONTROL MODE VF	NONE : no attempt is made to control the PWM modulation depth for variations in dc link voltage FIXED : the drive's output volts are maintained, regardless of variations in the dc link voltage. The drive's product code sets the default value for demanded maximum output voltage (see MOTOR VOLTAGE below) AUTOMATIC : the drive performs controlled over-fluxing during motor deceleration	0=NONE 1=FIXED 2=AUTOMATIC	0
5CL07	BOOST MODE FVF	Determines the relationship between fixed boost and terminal volts. There are two settings: FALSE produces the terminal volts profile shown below (with Auto Boost set to 0.0 %). In this mode AUTO BOOST (CL08) should also be set to provide optimum low speed performance. TRUE emulates the terminal volts profile provided by the SSD Drives' 601 product. This allows drop in replacement of the 601 by the 650V. AUTO BOOST (CL08) has no effect in this mode.	0=FALSE 1=TRUE	1
5CL08	AUTO BOOST F M VF	This parameter allows for load dependent, stator resistance voltage-drop compensation. This correctly fluxes the motor (under load conditions) at low output frequencies, thereby increasing available motor torque.. AUTO BOOST is only used when BOOST MODE is set to 0. The value of the AUTO BOOST parameter determines the level of additional volts supplied to the motor for 100% load. Setting the value of AUTO BOOST too high can cause the drive to enter current limit. If this occurs, the time taken for the drive to reach operating speed will be extended. Reducing the value of AUTO BOOST will eliminate this problem.	0.00 to 25.00 %	0.00 %
5CL09	ENERGY SAVING FVF	When set TRUE, the demanded volts are reduced to minimise energy consumption if the drive is operating in a steady state at light load.	0=FALSE 1=TRUE	0
5CL 10	MOTOR CURRENT M SV	This parameter contains the motor nameplate full-load line current	0.01 to 999.99A	product code dependent

6-6 Programming Your Application

MMI Parameters Table				
Display	Parameter	Description	Range	Default
5CL11	MOTOR POLES M SV	This parameter contains the number of motor poles, as supplied on the motor nameplate	2=2 pole 4=4 pole 6=6 pole 8=8 pole 10=10 pole 12=12 pole	4
5CL12	MOTOR VOLTAGE M	This parameter contains the motor nameplate voltage at base frequency	0.0 to 575.0V	product code dependent
5CL14	MAG CURRENT M	This parameter contains the motor model no-load line current as determined by the Autotune, or taken from the motor nameplate	0.01 to 999.99 A	product code dependent
5CL15	POWER M SV	This parameter contains the motor nameplate power.	0.00 to 355.00kW	product code dependent
5CL16	MOTOR CONNECTION M SV	This parameter contains the motor nameplate connection.	0= DELTA 1= STAR	1
5CL17	STATOR RES F M SV	This parameter contains the motor model per-phase stator resistance as determined by Autotune.	0.0000 to 250.0000Ω	product code dependent
5CL18	LEAKAGE INDUC F M SV	This parameter contains the motor model per-phase leakage inductance as determined by Autotune.	0.00 to 300.00mH	product code dependent
5CL19	MUTUAL INDUC F M SV	This parameter contains the motor model per-phase mutual inductance as determined by Autotune.	0.00 to 3000.00mH	product code dependent
5CL1A	ROTOR TIME CONST F M SV	This parameter contains the motor model rotor time constant as determined by Autotune.	10.00 to 3000.00ms	product code dependent
5CL20	AUTOTUNE MODE SV	Selects the Autotune operating mode.	0= STATIONARY 1= ROTATING	0
5CL21	AUTOTUNE ENABLE SV	Determines whether the Autotune sequence is operational or not. The Autotune sequence is operational when set to TRUE and the drive is run	0=FALSE 1=TRUE	0
5CL81	CURRENT LIMIT F	This parameter sets the level of motor current, as a % of MOTOR CURRENT (5CL10) at which the drive begins to take current limit action.	0.00 to 300.00%	300.00%
5CL82	POS TORQUE LIMIT F	This parameter sets the maximum allowed level of positive motor torque.	-500.0 to 500.0%	200.0%
5CL83	NEG TORQUE LIMIT F	This parameter sets the maximum allowed level of negative motor torque.	-500.0 to 500.0%	-200.0%
5CL84	STALL TRIP TYPE F	This parameter determines whether the stall trip operates on motor torque or motor current. FALSE = TORQUE, TRUE = CURRENT	0= FALSE 1= TRUE	1
5CL91	SPEED PROP GAIN F M SV	Sets the proportional gain of the loop. Speed error (revolutions per second) x proportional gain = torque percent.	0.00 to 300.00	product code dependent
5CL92	SPEED INT TIME F M SV	This is the integral time constant of the speed loop. A speed error which causes the proportional term to produce a torque demand T, will cause the integral term to also ramp up to a torque demand T after a time equal to "speed int time".	1 to 15000ms	product code dependent
5CL93	SPEED POS LIMIT F SV	This sets the upper limit of the speed demand.	-110.00 to 110.00%	110.00%
5CL94	SPEED NEG LIMIT F SV	This sets the lower limit of the speed demand.	-110.00 to 110.00%	-110.00%

MMI Parameters Table				
Display	Parameter	Description	Range	Default
SET::IN Menu				
5 IP01	DIN 1 INVERT	Inverts the value of the signal, TRUE or FALSE.	0= FALSE 1= TRUE	0
5 IP02	DIN 2 INVERT	As 5IP01	As 5IP01	0
5 IP03	DIN 3 INVERT	As 5IP01	As 5IP01	0
5 IP04	DIN 4 INVERT	As 5IP01	As 5IP01	0
5 IP05	DIN 5 INVERT	As 5IP01	As 5IP01	0
5 IP06	DIN 6 INVERT	As 5IP01	As 5IP01	0
5 IP07	DIN 7 INVERT	As 5IP01	As 5IP01	0
5 IP11	AIN 1 SCALE	TYPE SCALE OFFSET	-300.0 to 300.0%	100.0%
5 IP12	AIN 1 OFFSET	UNPROCESSED INPUT → X → + → VALUE	-300.0 to 300.0%	0.0%
5 IP13	AIN 1 TYPE	0 to 100% of selected TYPE	0= 0-10V 1= 0-5V	0
5 IP21	AIN 2 SCALE	TYPE SCALE OFFSET	-300.0 to 300.0%	100.0%
5 IP22	AIN 2 OFFSET	UNPROCESSED INPUT → X → + → VALUE	-300.0 to 300.0%	0.0%
5 IP23	AIN 2 TYPE	0 to 100% of selected TYPE	0= 0-10V 1= 0-5V 2= 0-20mA 3= 4-20mA	3
5 IPd1	DIN 1 VALUE	The TRUE or FALSE input (after any inversion)	0=FALSE 1=TRUE	0
5 IPd2	DIN 2 VALUE	The TRUE or FALSE input (after any inversion)	0=FALSE 1=TRUE	0
5 IPd3	DIN 3 VALUE	The TRUE or FALSE input (after any inversion)	0=FALSE 1=TRUE	0
5 IPd4	DIN 4 VALUE	The TRUE or FALSE input (after any inversion)	0=FALSE 1=TRUE	0
5 IPd5	DIN 5 VALUE	The TRUE or FALSE input (after any inversion)	0=FALSE 1=TRUE	0
5 IPd6	DIN 6 VALUE	The TRUE or FALSE input (after any inversion)	0=FALSE 1=TRUE	0
5 IPd7	DIN 7 VALUE	The TRUE or FALSE input (after any inversion)	0=FALSE 1=TRUE	0
5 IPA1	AIN 1 VALUE	The input reading with scaling and offset applied	—.x%	—.x%
5 IPA2	AIN 2 VALUE	The input reading with scaling and offset applied	—.x%	—.x%

SET::OUT Menu				
5 OP01	AOUT 1 SOURCE	ANALOG OUTPUT 0 NONE 1 DEMAND % 2 CURRENT % 3 PI ERROR % 4 RAISE/LOWER OUTPUT	SCALE 5 OP02 OFFSET 5 OP03 ABSOLUTE 5 OP04	0= NONE 1= DEMAND 2= CURRENT 3= PID ERROR 4= RAISE/LOWER OUTPUT
5 OP02	AOUT 1 SCALE	SCALE OFFSET ABS	-300.00 to 300.00%	100.00%
5 OP03	AOUT 1 OFFSET	VALUE → X → + → X	-300.00 to 300.00%	0.00%
5 OP04	AOUT 1 ABSOLUTE	100% CLAMP 0%	0= FALSE (not absolute) 1= TRUE (absolute)	1
5 OP05	AOUT 1 VALUE		-300.0 to 300.0%	0.0%

6-8 Programming Your Application

MMI Parameters Table				
Display	Parameter	Description	Range	Default
5OP21	DOUT 2 SOURCE Refer to Configuring Terminals 9 & 10 (Digital Input/Output), page 5-13.	DIN4 / DOUT2 0 NONE 1 HEALTH 2 TRIPPED 3 RUNNING 4 AT ZERO 5 AT SPEED 6 AT LOAD	0= NONE 1= HEALTH 2= TRIPPED 3= RUNNING 4= AT ZERO 5= AT SPEED 6= AT LOAD	0
5OP22	DOUT 2 INVERT	(OUTPUT) As ^S IP01. Set to 0 for applications 1 & 5.	As ^S IP01	0
5OP23	DOUT 2 VALUE F	The TRUE or FALSE output demand.	0=FALSE 1=TRUE	0
5OP31	RELAY SOURCE	NONE : Relay is open Relay is closed when: HEALTH : the Run signal is not present, or no trip is active TRIPPED : a trip is present RUNNING : the motor is running AT ZERO : the output frequency is below 1% of MAX SPEED (^P 2) AT SPEED : the output frequency is at or near Setpoint and within ±1% of MAX SPEED, set by (^P 2). For example: if MAX SPEED = 50Hz and Setpoint = 30Hz, then 1% of MAX SPEED = 0.5Hz. So AT LOAD is True between 30 ±0.5Hz. AT LOAD : the magnitude of the output torque is greater than or equal to the torque level set in ST 42	As ^S OP21	1
5OP32	RELAY INVERT	Inverts the value of the signal, TRUE or FALSE.	0=FALSE 1=TRUE	0
5OP33	RELAY VALUE F	The TRUE or FALSE output demand.	0=FALSE 1=TRUE	0

SET::TRIP Menu

5LOOP	DISABLE LOOP	Disables LOST I LOOP trip (4-20mA)	0= TRIP ENABLED 1= TRIP DISABLED	1
5t3	AIN2 OVERLOAD	Disables the overload trip (Terminal 3)	As ^S LOOP	0
5StLL	DISABLE STALL	Disables STALL trip	As ^S LOOP	0
5Ot	DISABLE MOTOR OVERTEMP	Disables the motor thermistor trip	As ^S LOOP	0
5It	INVERSE TIME	Disables the inverse time trip	As ^S LOOP	1
5db r	DYNAMIC BRAKE RESISTOR	Disables the dynamic brake resistor trip	As ^S LOOP	1
5db S	DYNAMIC BRAKE SWITCH	Disables the dynamic brake switch trip	As ^S LOOP	1
5SPd	SPEED FEEDBACK	Disables the speed feedback trip	As ^S LOOP	0
5OSPd	OVERSPEED	Disables the overspeed trip	As ^S LOOP	0
5dI SP	DISPLAY (KEYPAD)	Disables the display (keypad) trip	As ^S LOOP	0
5dC RP	DC LINK RIPPLE F	Disables the DC link ripple trip	As ^S LOOP	0



MMI Parameters Table				
Display	Parameter	Description	Range	Default
SET::SERL Menu				
\$SE01	REMOTE COMMS SEL F	Selects the type of remote communications mode: 0 : FALSE, and in REMOTE mode then control is from the terminals. 1 : TRUE, and in REMOTE mode then control is from the communications.	0=FALSE 1=TRUE	0
\$SE02	COMMS TIMEOUT F	Sets the maximum time allowed between refreshing the COMMS COMMAND parameter. The drive will trip if this time is exceeded. Set the time to 0.00 seconds to disable this feature.	0.0 to 600.0s	0.0s
\$SE03	COMMS ADDRESS F	The drives identity address. Note: if set to 0, it will only respond to broadcast messages.	0 to 255	0
\$SE04	BAUD RATE F	Selects the Baud Rate for the MODBUS protocol.	0 : 1200 1 : 2400 2 : 4800 3 : 7200 4 : 9600 5 : 14400 6 : 19200 7 : 38400 8 : 57600	4
\$SE05	PARITY F	Selects the Parity for the MODBUS protocol.	0= NONE 1= ODD 2= EVEN	0
\$SE06	REPLY DELAY ms	The time in milliseconds between the drive receiving the complete request from the communications master (PLC/PC) and replying to this request.	0 to 200	5
\$SE07	OP PORT PROTOCOL F	Selects the protocol to be used by the keypad port on the front of the drive. When EIBISYNC ASCII is selected, BAUD RATE is 19200 and PARITY is EVEN. FIELDBUS is reserved for future use.	0= AUTOMATIC 1= KEYPAD 2=EIBISYNC ASCII 3= MODBUS 4= FIELDBUS	0
\$SE08	P3 PORT PROTOCOL F	Selects the protocol to be used by the RS232 programming port on the drive's control board. When EIBISYNC ASCII is selected, BAUD RATE is 19200 and PARITY is EVEN. FIELDBUS is reserved for future use.	As \$SE07	0

SET::SETP Menu				
\$SE01	JOG ACCEL TIME	As ^P 4, for Jog	0.0 to 3000.0s	1.0
\$SE02	JOG DECEL TIME	As ^P 5, for Jog	0.0 to 3000.0s	1.0
\$SE03	RAMP TYPE	Selects the ramp type	0=LINEAR 1=S	0
\$SE04	S RAMP JERK	Rate of change of acceleration of the curve in units per second ³	0.01 to 100.00 s ³	10.00
\$SE05	S RAMP CONTINUOUS	When TRUE and the S ramp is selected, forces a smooth transition if the speed setpoint is changed when ramping. The curve is controlled by the S RAMP JERK parameter. When FALSE, there is an immediate transition from the old curve to the new curve	0=FALSE 1=TRUE	1
\$SE06	MIN SPEED MODE	Selects a mode to determine how the drive will follow a reference: Proportional : minimum limit, Linear : between minimum and maximum.	0=PROP.W/MIN. 1=LINEAR (used by the 601 product)	0
\$SE11	SKIP FREQUENCY 1	This parameter contains the centre frequency of skip band 1 in Hz	0.0 to 240.0 Hz	0.0
\$SE12	SKIP FREQUENCY BAND 1	The width of skip band 1 in Hz	0.0 to 60.0 Hz	0.0

6-10 Programming Your Application

MMI Parameters Table				
Display	Parameter	Description	Range	Default
55t13	SKIP FREQUENCY 2	This parameter contains the centre frequency of skip band 2 in Hz	0.0 to 240.0 Hz	0.0
55t14	SKIP FREQUENCY BAND 2	The width of skip band 2 in Hz	0.0 to 60.0 Hz	0.0
55t21	AUTO RESTART ATTEMPTS	Determines the number of restarts that will be permitted before requiring an external fault reset	0 to 10	0
55t22	AUTO RESTART DELAY	Determines the delay between restart attempts for a trip included in AUTO RESTART TRIGGERS and AUTO RESTART TRIGGERS+. The delay is measured from all error conditions clearing	0.0 to 600.0 s	10.0
55t23	AUTO RESTART TRIGGERS	Allows Auto Restart to be enabled for a selection of trip conditions. Refer to Chapter 6: "Trips and Fault Finding" - Hexadecimal Representation of Trips	0x0000 to 0xFFFF	0x0000
55t24	AUTO RESTART TRIGGERS+	Allows Auto Restart to be enabled for a selection of trip conditions. Refer to Chapter 6: "Trips and Fault Finding" - Hexadecimal Representation of Trips	0x0000 to 0xFFFF	0x0000
55t31	DB ENABLE	Enables operation of the dynamic braking.	0=FALSE 1=TRUE	1
55t32	DB RESISTANCE	The value of the load resistance.	1 to 1000	product code dependent
55t33	DB POWER	The power that the load resistance may continually dissipate.	0.1 to 510.0 kW	product code dependent
55t34	DB OVER-RATING	Multiplier that may be applied to DB POWER for power overloads lasting no more than 1 second.	1 to 40	25
55t41	TORQUE FEEDBACK	Shows the estimated motor torque, as a percentage of rated motor torque.	— .xx %	— .xx %
55t42	TORQUE LEVEL	This parameter sets the value of load at which AT LOAD becomes TRUE. AT LOAD is selectable by the digital inputs. Refer to ^S OP21 and ^S OP31. 100% = rated torque for the motor.	-300.0 to 300.0 %	100.0 %
55t43	USE ABS TORQUE F	When TRUE, the direction of rotation is ignored. In this case, the comparison level should always be positive. When FALSE, the direction of rotation is not ignored. Driving a load in the reverse direction gives a negative value for torque. In this case, the comparison level may be positive or negative.	0=FALSE 1=TRUE	0
55t51	LOCAL MIN SPEED F	The magnitude of the minimum setpoint that will be used when running in Local Mode.	0.0 to 100.0 %	0.0 %

MMI Parameters Table

Display	Parameter	Description	Range	Default	
55t52	ENABLED KEYS F	The following keys on the 6901 keypad can be enabled or disabled separately. The combination produces the parameter setting as in the table below. The default of FFFF enables all keys.	0000 to FFFF	FFFF	
 6901	Parameter Setting	RUN	L/R	JOG	DIR
	0000	-	-	-	-
	0010	-	-	-	ENABLED
	0020	-	-	ENABLED	-
	0030	-	-	ENABLED	ENABLED
	0040	-	ENABLED	-	-
	0050	-	ENABLED	-	ENABLED
	0060	-	ENABLED	ENABLED	-
	0070	-	ENABLED	ENABLED	ENABLED
	0080	ENABLED	-	-	-
	0090	ENABLED	-	-	ENABLED
	00A0	ENABLED	-	ENABLED	-
	00B0	ENABLED	-	ENABLED	ENABLED
	00C0	ENABLED	ENABLED	-	-
	00D0	ENABLED	ENABLED	-	ENABLED
	00E0	ENABLED	ENABLED	ENABLED	-
	00F0	ENABLED	ENABLED	ENABLED	ENABLED
 6511	 6521	When using the standard 6511 and 6521 keypad, disabling the DIR key prevents the local setpoint going negative (for reverse). Similarly, disabling the L/R key prevents the drive being changed from Local to Remote, or Remote to Local modes.			
55t98	APPLICATION LOCK F	Setting this parameter to TRUE prevents editing of parameter ^P 1. Set this parameter to FALSE to edit parameter ^P 1.	0=FALSE 1=TRUE	0	
55t99	DETAILED MENUS	Selects Full menu detail when TRUE. The additional parameters in the Full menus are indicated in this table by F.	0=FALSE 1=TRUE	0	

SET::ENC Menu

5EN01	ENC MODE F	Set this parameter to the requirements for your encoder: 0 : QUADRATURE (using digital inputs 6 & 7, ENCA and ENCB respectively) 1 : CLOCK/DIR (using digital inputs 6 & 7, ENCA and ENCB respectively) 2 : CLOCK (using digital input 6, ENCA)	0= QUADRATURE 1= CLOCK/DIR 2= CLOCK	0
5EN02	ENC RESET F	When TRUE the POSITION and SPEED outputs are set (and held) at zero.	0=FALSE 1=TRUE	0
5EN03	ENC INVERT F	When TRUE, changes the sign of the measured speed and the direction of the position count.	0=FALSE 1=TRUE	0
5EN04	ENC LINES F	The number of lines must be set to match the type of encoder being used. Incorrect setting of this parameter will result in an erroneous speed measurement.	100 to 10000	100

6-12 Programming Your Application

MMI Parameters Table				
Display	Parameter	Description	Range	Default
5EN05	ENC SPEED SCALE F	<p>This parameter allows the output "speed" to be scaled to any value the user requires. With a default value of 1.00, the output "speed" is measured in revs per second. Changing the ENC SPEED SCALE value to 60.00 will provide an output in revs per minute.</p> <p>To provide an output in percent of the motor maximum speed, where maximum speed is the maximum speed your motor will run in rpm, the ENC SPEED SCALE parameter should be set to the result of:</p> $\frac{6000}{\text{maximum speed (rpm)}}$	0.00 to 300.00	1.00
5EN06	ENC SPEED F	Speed feedback, in units defined by the ENC SPEED SCALE parameter.	—.x	—.x

Configuring Terminals 9 & 10 (Digital Input/Output)

Terminal 10 can be operated as digital input DIN 4 or digital output DOUT2. It is configured via the keypad or ConfigEd Lite (or other suitable programming tool). The default for terminal 10 is to operate as a digital input, and the input logic is non-inverted.

Terminal 9 can be operated as digital input DIN3 or digital output DOUT1, however, it can only be configured via ConfigEd Lite (or other suitable programming tool). The default for terminal 9 is to operate as a digital input, and the input logic is non-inverted.

Configure for use as a Digital Input (default)

For example, to use terminal 10 as an input, the output circuitry must be disabled by setting ^SOP21 and ^SOP22 to zero. You can invert this logic using parameter ^SIP04.

Parameter	Setting
^S OP21 DOUT2 SOURCE	0
^S OP22 DOUT2 INVERT	0
^S IP04 DIN4 INVERT	Default is 0, setting to 1 inverts the input logic

Configure for use as a Digital Output

For example, to use terminal 10 as an output, select ^SOP21 to be 1, 2, 3, 4, 5 or 6. For instance, you could set parameter ^SOP21 to 3 to have the output go high (24V) whenever the motor is running, operating an external relay or lamp. You can invert this logic using parameter ^SOP22.

Parameter	Setting	
^S OP21 DOUT2 SOURCE	<p><i>The output is high when:</i></p> <p>1 = HEALTH The Run signal is not present, or no trip is active</p> <p>2 = TRIPPED A trip is present</p> <p>3 = RUNNING The motor is running</p>	
	4 = AT ZERO The output frequency is below 1% of MAX SPEED (^P 2)	
	5 = AT SPEED The output frequency is at or near Setpoint and within ±1% of MAX SPEED, set by (^P 2). For example: if MAX SPEED = 50Hz and Setpoint = 30Hz, then 1% of MAX SPEED = 0.5Hz. So AT LOAD is True between 30 ±0.5Hz.	
	6 = AT LOAD The magnitude of the output torque is greater than or equal to the torque level set in ^S ST42	
	Always set ^S IP04 to 0 if using Applications 1 and 5 – refer to Chapter 12.	
	^S OP22 DOUT2 INVERT	Default is 0, setting to 1 inverts the output logic

PID - Tuning Your Drive

Parameters ^P501 to ^P508: PID is used to control the response of any closed loop system. It is used specifically in system applications involving the control of drives to provide zero steady state error between Setpoint and Feedback, together with good transient performance.

Proportional Gain (^P501)

This is used to adjust the basic response of the closed loop control system. The PI error is multiplied by the Proportional Gain to produce an output.

6-14 Programming Your Application

Integral (^P502)

The Integral term is used to reduce steady state error between the setpoint and feedback values of the PI. If the integral is set to zero, then in most systems there will always be a steady state error.

Derivative (^P503)

This is used to correct for certain types of control loop instability, and therefore improve response. It is sometimes used when heavy or large inertia rolls are being controlled. The derivative term has an associated filter to suppress high frequency signals.

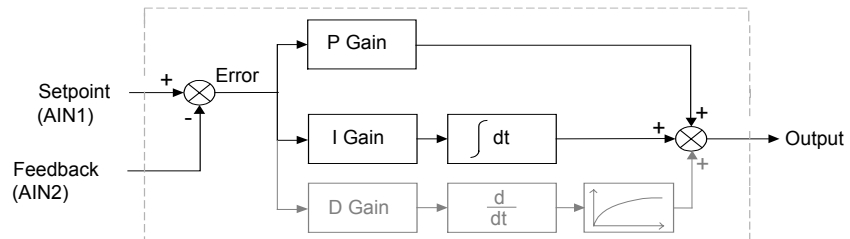

- Functions as P, PI, PID controller
- Single symmetric limit on output

A Method for Setting-up the PI Gains

The gains should be set-up so that a critically damped response is achieved for a step change in setpoint. An underdamped or oscillatory system can be thought of as having too much gain, and an overdamped system has too little.

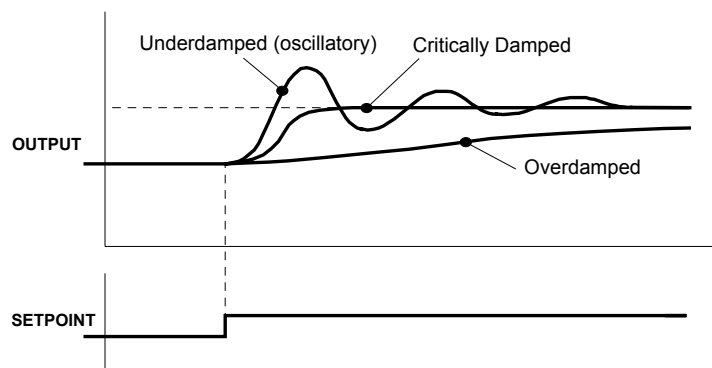

To set up the P gain, set the I gain to zero. Apply a step change in setpoint that is typical for the System, and observe the response. Increase the gain and repeat the test until the system becomes oscillatory. At this point, reduce the P gain until the oscillations disappear. This is the maximum value of P gain achievable.

If a steady state error is present, i.e. the feedback never reaches the setpoint value, the I gain needs to be increased. As before, increase the I gain and apply the step change. Monitor the output. If the output becomes oscillatory, reduce the P gain slightly. This should reduce the steady state error. Increasing the I gain further may reduce the time to achieve zero steady state error.

These values of P and I can now be adjusted to provide the exact response required for this step change.

Auto Restart

Parameters ^SST21 to ^SST24 provide the facility to automatically reset a choice of trip events and restart the drive with a programmed number of attempts. If the drive is not successfully started, a manual or remote trip reset is required.

The number of attempted restarts are recorded. This count is cleared after a trip-free period of operation (5 minutes or 4 x AUTO RESTART DELAY, whichever is the longer); or after a successful manual or remote trip reset; or by removing the Run signal (Terminal 7, DIN1).

Refer to Chapter 7: "Trips and Fault Finding" - Hexadecimal Representation of Trips.

Skip Frequencies

Parameters ^SST11 to ^SST14 control two programmable skip frequencies that can prevent the drive from operating at frequencies that cause mechanical resonance in the load.

- Enter the value of the frequency that causes the resonance into the SKIP FREQUENCY parameter.
- Enter a width for the skip band into the SKIP FREQUENCY BAND parameter.

The drive will then avoid sustained operation within the forbidden band as shown in the diagram. The skip frequencies are symmetrical and thus work in forward and reverse.

Setting SKIP FREQUENCY or SKIP FREQUENCY BAND to 0 disables the corresponding band.

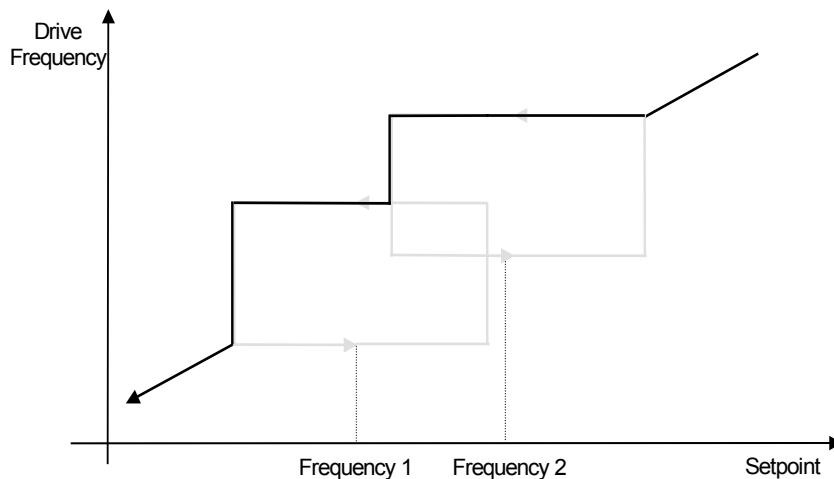
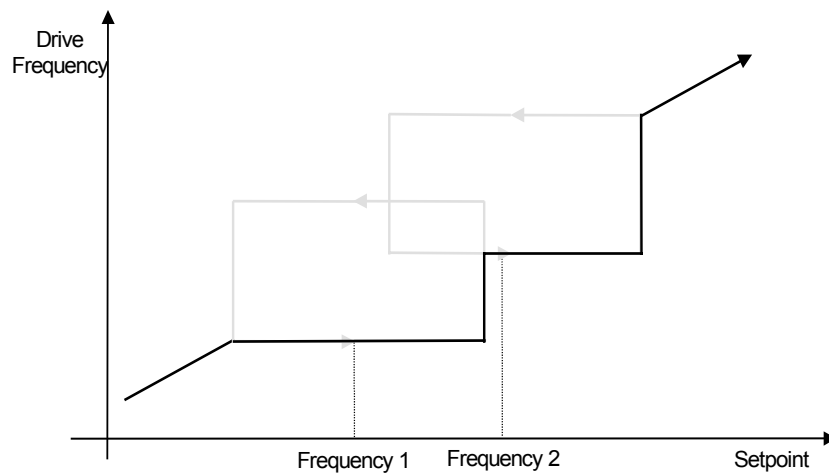
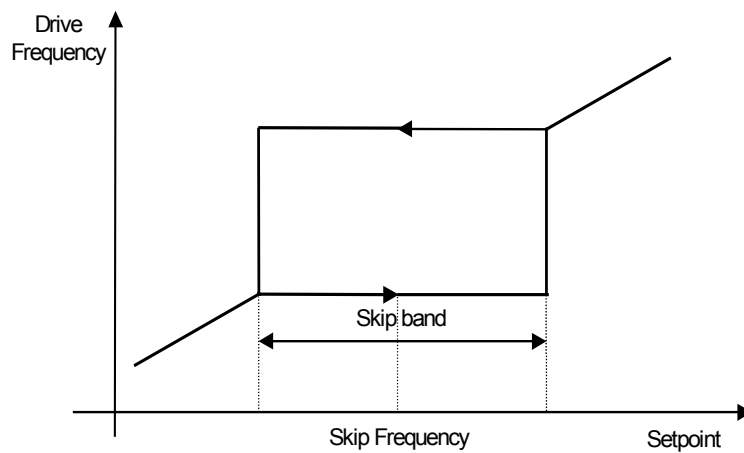

6-16 Programming Your Application

Minimum Speed Mode

There are two operating modes for the minimum speed feature.

Proportional with Minimum

In this mode the speed setpoint is clamped to be between the minimum speed value (P3) and 100%. This is the default for the minimum speed feature.

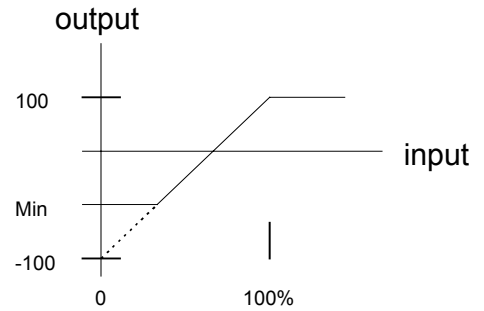

Linear

In this mode the speed setpoint is first clamped to be in the range 0 to 100%. It is then rescaled so that the output goes linearly between the minimum speed value (P3) and 100% for an input setpoint that goes between 0% and 100%. If the minimum speed value (P3) is negative the speed setpoint will be internally set to 0%.

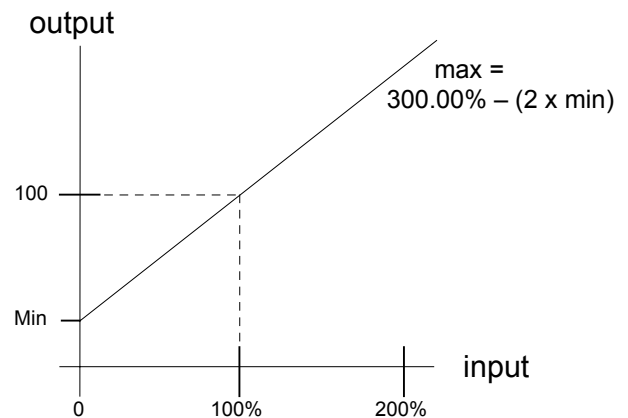

Product-Related Default Values

All examples given in this book are based on a UK, 230V, 50Hz, 0.25kW drive. This manual provides information about each parameter accessible using the keypad, or MMI (Man Machine Interface). For more information about these and additional parameters accessible using ConfigEd Lite (or other suitable programming tool), refer to the 650V Software Product Manual on our web site: www.SSDdrives.com.

* Frequency Dependent Parameters

These parameter values (marked with "*" in the Application diagrams) are dependent upon the drive's "default frequency".

Changing the "default frequency" parameter from 50Hz to 60Hz, and vice versa, causes the values of the parameters in the table below to be changed.

To change the "default frequency", power-down the drive. Power-up the drive holding down the STOP and DOWN keys on the keypad. Release the keys to display the ° 0.01 parameter.

Caution

You are now in a menu containing some sensitive and important parameters.

Press the UP key to display the ° 0.02 parameter. Press the M key. The values for this parameter are: 0 = 50Hz default, 1 = 60Hz default. Select the setting using the UP/DOWN keys and then press the E key. Power-down the drive and power-up again holding down the UP and DOWN keys. This resets **ALL** parameters to their correct default values, including Motor Parameters.

Frequency Dependent Defaults					
Display	Parameter	Function Block	Tag	50Hz Operation	60Hz Operation
P 7	BASE FREQUENCY	MOTOR DATA	1159	50Hz	60Hz
5CL02	NAMEPLATE RPM	MOTOR DATA	83	#	1750 RPM
5CL12	MOTOR VOLTAGE	MOTOR DATA	1160	*	*
P 2	MAX SPEED	REFERENCE	57	50Hz	60Hz
5CL16	MOTOR CONNECTION	MOTOR DATA	124	STAR	STAR

The correct value is selected for the size of drive - refer to the Power Dependent Parameters table below
 * The correct value is selected for the drive, however, when 60Hz is selected the 400V unit = 460V

6-18 Programming Your Application

** Power Dependent Parameters

These parameters (marked with “**”) in the Application diagrams) are set to a value depending on the drive's overall “power-build” indicated by the Product Code. We recommend that you do not change the Product Code.

230V Build Power Dependent Defaults								
Parameter	Function Block	Tag	Frame 1				Frame 2	
			0.25kW	0.37kW	0.55kW	0.75kW	1.1kW	1.5kW
POWER	MOTOR DATA	1158	0.25 kw	0.37 kw	0.55 kw	0.75 kw	1.10 kw	1.50 kw
MOTOR CURRENT	MOTOR DATA	64	1.50 A	2.20 A	3.00 A	4.00 A	5.50 A	7.00 A
MAG CURRENT	MOTOR DATA	65	0.80 A	0.80 A	1.04 A	1.36 A	2.50 A	3.41 A
NAMEPLATE RPM	MOTOR DATA	83	1380.0 RPM	1380.0 RPM	1400.0 RPM	1400.0 RPM	1420.0 RPM	1420.0 RPM
MOTOR VOLTAGE	MOTOR DATA	1160	230.0 V	230.0 V	230.0 V	230.0 V	230.0 V	230.0 V
POWER FACTOR	MOTOR DATA	242	0.70	0.70	0.70	0.70	0.71	0.78
STATOR RES	MOTOR DATA	119	5.2060 ohms	5.2060 ohms	3.8177 ohms	2.9367 ohms	1.5907 ohms	1.1687 ohms
LEAKAGE INDUC	MOTOR DATA	120	110.47 mH	110.47 mH	81.01 mH	62.32 mH	33.76 mH	24.80 mH
MUTUAL INDUC	MOTOR DATA	121	441.90 mH	441.90 mH	324.06 mH	249.28 mH	135.02 mH	99.20 mH
ROTOR TIME CONST	MOTOR DATA	1163	91.17 ms	91.17 ms	109.40 ms	109.40 ms	136.75 ms	136.75 ms
BRAKE POWER	DYNAMIC BRAKING	78	0.1 kW	0.1 kW	0.1 kW	0.1 kW	0.1 kW	0.1 kW
FREQUENCY	INJ BRAKING	577	9.0 Hz	9.0 Hz	9.0 Hz	9.0 Hz	9.0 Hz	9.0 Hz
DEFLUX TIME	INJ BRAKING	710	0.1 s	0.1 s	0.1 s	0.1 s	0.1 s	0.1 s
BASE VOLTS	INJ BRAKING	739	100.00 %	100.00 %	100.00 %	100.00 %	100.00 %	100.00 %
DC LEVEL	INJ BRAKING	581	10.0 %	10.0 %	10.0 %	10.0 %	3.0 %	3.0 %
DC PULSE	INJ BRAKING	579	2.0 s	2.0 s	2.0 s	2.0 s	2.0 s	2.0 s
FINAL DC PULSE	INJ BRAKING	580	1.0 s	1.0 s	1.0 s	1.0 s	1.0 s	1.0 s
FIXED BOOST	FLUXING	107	5.00%	5.00%	5.00%	5.00%	5.00%	5.00%
ACCEL TIME	REFERENCE RAMP	258	10.0 s	10.0 s	10.0 s	10.0 s	10.0 s	10.0 s
DECEL TIME	REFERENCE RAMP	259	10.0 s	10.0 s	10.0 s	10.0 s	10.0 s	10.0 s
DEFLUX DELAY	PATTERN GEN	100	0.5 s	0.5 s	0.5 s	0.5 s	1.0 s	1.0 s
SEARCH VOLTS	FLYCATCHING	573	9.00 %	9.00 %	9.00 %	9.00 %	9.00 %	9.00 %
SEARCH BOOST	FLYCATCHING	32	40.00 %	40.00 %	40.00 %	40.00 %	40.00 %	40.00 %
SEARCH TIME	FLYCATCHING	574	5.0 s	5.0 s	5.0 s	5.0 s	5.0 s	5.0 s
REFLUX TIME	FLYCATCHING	709	3.0 s	3.0 s	3.0 s	3.0 s	3.0 s	3.0 s
OVERLOAD	MOTOR DATA	1164	2.0	2.0	2.0	2.0	2.0	2.0
SPEED PROP GAIN	SPEED LOOP	1187	20	20	20	20	20	20
SPEED INT TIME	SPEED LOOP	1188	500. ms	500. ms	500. ms	500. ms	500. ms	500. ms
MOTOR CONNECTION	MOTOR DATA	124	1 : STAR	1 : STAR	1 : STAR	1 : STAR	1 : STAR	1 : STAR
BRAKE RESISTANCE	DYNAMIC BRAKING	77	500	500	500	500	500	500
BOOST MODE	FLUXING	1058	1	1	1	1	1	1

400V Build Power Dependent Defaults			Frame 2					
Parameter	Function Block	Tag	0.37kW	0.55kW	0.75kW	1.1kW	1.5kW	2.2kW
POWER	MOTOR DATA	1158	0.37 kw	0.55 kw	0.75 kw	1.10 kw	1.50 kw	2.20 kw
MOTOR CURRENT	MOTOR DATA	64	1.50 A	2.00 A	2.50 A	3.50 A	4.50 A	5.50 A
MAG CURRENT	MOTOR DATA	65	0.44 A	0.60 A	0.78 A	1.00 A	1.44 A	1.96 A
NAMEPLATE RPM	MOTOR DATA	83	1380.0 RPM	1400.0 RPM	1400.0 RPM	1420.0 RPM	1420.0 RPM	1420.0 RPM
MOTOR VOLTAGE	MOTOR DATA	1160	400.0 V	400.0 V	400.0 V	400.0 V	400.0 V	400.0 V
POWER FACTOR	MOTOR DATA	242	0.70	0.70	0.70	0.71	0.71	0.78
STATOR RES	MOTOR DATA	119	15.7459 ohms	11.5470 ohms	8.8823 ohms	1.5907 ohms	4.8113 ohms	3.5348 ohms
LEAKAGE INDUC	MOTOR DATA	120	334.14 mH	245.04 mH	188.49 mH	33.76 mH	102.10 mH	75.01 mH
MUTUAL INDUC	MOTOR DATA	121	1336.55 mH	980.14 mH	753.95 mH	135.02 mH	408.39 mH	300.04 mH
ROTOR TIME CONST	MOTOR DATA	1163	91.17 ms	109.40 ms	109.40 ms	136.75 ms	136.75 ms	136.75 ms
BRAKE POWER	DYNAMIC BRAKING	78	0.1 kW	0.1 kW	0.1 kW	0.1 kW	0.1 kW	0.1 kW
FREQUENCY	INJ BRAKING	577	9.0 Hz	9.0 Hz	9.0 Hz	9.0 Hz	9.0 Hz	9.0 Hz
DEFLUX TIME	INJ BRAKING	710	0.1 s	0.1 s	0.1 s	0.1 s	0.1 s	0.1 s
BASE VOLTS	INJ BRAKING	739	100.00 %	100.00 %	100.00 %	100.00 %	100.00 %	100.00 %
DC LEVEL	INJ BRAKING	581	3.0 %	3.0 %	3.0 %	3.0 %	3.0 %	3.0 %
DC PULSE	INJ BRAKING	579	2.0 s	2.0 s	2.0 s	2.0 s	2.0 s	2.0 s
FINAL DC PULSE	INJ BRAKING	580	1.0 s	1.0 s	1.0 s	1.0 s	1.0 s	1.0 s
FIXED BOOST	FLUXING	107	5.00%	5.00%	5.00%	5.00%	5.00%	5.00%
ACCEL TIME	REFERENCE RAMP	258	10.0 s	10.0 s	10.0 s	10.0 s	10.0 s	10.0 s
DECEL TIME	REFERENCE RAMP	259	10.0 s	10.0 s	10.0 s	10.0 s	10.0 s	10.0 s
DEFLUX DELAY	PATTERN GEN	100	1.0 s	1.0 s	1.0 s	1.0 s	1.0 s	1.0 s
SEARCH VOLTS	FLYCATCHING	573	9.00 %	9.00 %	9.00 %	9.00 %	9.00 %	9.00 %
SEARCH BOOST	FLYCATCHING	32	40.00 %	40.00 %	40.00 %	40.00 %	40.00 %	40.00 %
SEARCH TIME	FLYCATCHING	574	5.0 s	5.0 s	5.0 s	5.0 s	5.0 s	5.0 s
REFLUX TIME	FLYCATCHING	709	3.0 s	3.0 s	3.0 s	3.0 s	3.0 s	3.0 s
OVERLOAD	MOTOR DATA	1164	2.0	2.0	2.0	2.0	2.0	2.0
SPEED PROP GAIN	SPEED LOOP	1187	20	20	20	20	20	20
SPEED INT TIME	SPEED LOOP	1188	500. ms	500. ms	500. ms	500. ms	500. ms	500. ms
MOTOR CONNECTION	MOTOR DATA	124	1 : STAR	1 : STAR	1 : STAR	1 : STAR	1 : STAR	1 : STAR
BRAKE RESISTANCE	DYNAMIC BRAKING	77	500	500	500	200	200	200
BOOST MODE	FLUXING	1058	1	1	1	1	1	1

6-20 Programming Your Application

400V Build Power Dependent Defaults			Frame 3			
Parameter	Function Block	Tag				
POWER	MOTOR DATA	1158	3.00 kw	4.00 kw	5.50 kw	7.50 kw
MOTOR CURRENT	MOTOR DATA	64	6.80 A	9.00 A	12.00 A	16.00 A
MAG CURRENT	MOTOR DATA	65	2.36 A	3.36 A	3.39 A	4.38 A
NAMEPLATE RPM	MOTOR DATA	83	1420.0 RPM	1420.0 RPM	1445.0 RPM	1450.0 RPM
MOTOR VOLTAGE	MOTOR DATA	1160	400.0 V	400.0 V	400.0 V	400.0 V
POWER FACTOR	MOTOR DATA	242	0.8	0.8	0.8	0.8
STATOR RES	MOTOR DATA	119	2.0620 ohms	2.0620 ohms	1.3625 ohms	1.0545 ohms
LEAKAGE INDUC	MOTOR DATA	120	43.76 mH	43.76 mH	43.37 mH	33.57 mH
MUTUAL INDUC	MOTOR DATA	121	175.03 mH	175.03 mH	173.48 mH	134.27 mH
ROTOR TIME CONST	MOTOR DATA	1163	136.75 ms	136.75 ms	276.04 ms	303.65 ms
BRAKE POWER	DYNAMIC BRAKING	78	0.2 kW	0.2 kW	0.5 kW	0.5 kW
FREQUENCY	INJ BRAKING	577	9.0 Hz	9.0 Hz	9.0 Hz	9.0 Hz
DEFLUX TIME	INJ BRAKING	710	0.5 s	0.5 s	0.5 s	0.5 s
BASE VOLTS	INJ BRAKING	739	100.00 %	100.00 %	100.00 %	100.00 %
DC LEVEL	INJ BRAKING	581	3.0 %	3.0 %	3.0 %	3.0 %
DC PULSE	INJ BRAKING	579	2.0 s	2.0 s	2.0 s	2.0 s
FINAL DC PULSE	INJ BRAKING	580	1.0 s	1.0 s	1.0 s	1.0 s
FIXED BOOST	FLUXING	107	5.00%	5.00%	5.00%	5.00%
ACCEL TIME	REFERENCE RAMP	258	10.0 s	10.0 s	10.0 s	10.0 s
DECEL TIME	REFERENCE RAMP	259	10.0 s	10.0 s	10.0 s	10.0 s
DEFLUX DELAY	PATTERN GEN	100	2.0 s	2.0 s	2.0 s	2.0 s
SEARCH VOLTS	FLYCATCHING	573	9.00 %	9.00 %	9.00 %	9.00 %
SEARCH BOOST	FLYCATCHING	32	40.00 %	40.00 %	40.00 %	40.00 %
SEARCH TIME	FLYCATCHING	574	5.0 s	5.0 s	5.0 s	5.0 s
REFLUX TIME	FLYCATCHING	709	3.0 s	3.0 s	3.0 s	3.0 s
OVERLOAD	MOTOR DATA	1164	2.0	2.0	2.0	2.0
SPEED PROP GAIN	SPEED LOOP	1187	20	20	20	20
SPEED INT TIME	SPEED LOOP	1188	500. ms	500. ms	500. ms	500. ms
MOTOR CONNECTION	MOTOR DATA	124	1 : STAR	1 : STAR	1 : STAR	1 : STAR
BRAKE RESISTANCE	DYNAMIC BRAKING	77	100	100	56	56
BOOST MODE	FLUXING	1058	1	1	1	1

TRIPS AND FAULT FINDING

Trips

Trip Warning Message

The trip display message is flashed repeatedly on the screen to warn of an imminent trip. Some trip conditions need time to take effect. The warning can allow you time to rectify the situation.

The message will clear when you use the keypad, but after a short time will reappear until the problem is resolved, or the drive trips.

What Happens when a Trip Occurs

When a trip occurs, the drive's power stage is immediately disabled causing the motor and load to coast to a stop. The trip is latched until action is taken to reset it. This ensures that trips due to transient conditions are captured and the drive is disabled, even when the original cause of the trip is no longer present.

Keypad Indications

If a trip condition is detected the activated alarm is displayed on the MMI display.

Resetting a Trip Condition

All trips must be reset before the drive can be re-enabled. A trip can only be reset once the trip condition is no longer active, i.e. a trip due to a heatsink over-temperature will not reset until the temperature is below the trip level.

You can reset the trip as follows:

1. Press the  (STOP) key to reset the trip and clear the alarm from the display.
2. Remove and then re-apply the RUN command and the drive will run normally.

In remote mode, success is indicated by displaying .

Using the Keypad to Manage Trips

Trip Messages

If the drive trips, then the display immediately shows a message indicating the reason for the trip. The possible trip messages are given in the table below.

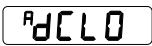
ID	Trip Name	Possible Reason for Trip
1	OVERVOLTAGE 	<i>The drive internal dc link voltage is too high:</i> <ul style="list-style-type: none"> • The supply voltage is too high • Trying to decelerate a large inertia load too quickly; DECEL TIME time too short The brake resistor is open circuit
2	UNDERVOLTAGE 	<i>DC link low trip:</i> Supply is too low/power down

7-2 Trips and Fault Finding

ID	Trip Name	Possible Reason for Trip
3	OVERCURRENT A OC	<i>The motor current being drawn from the drive is too high:</i> <ul style="list-style-type: none"> Trying to accelerate a large inertia load too quickly; ACCEL TIME time too short Trying to decelerate a large inertia load too quickly; DECEL TIME time too short Application of shock load to motor Short circuit between motor phases Short circuit between motor phase and earth Motor output cables too long or too many parallel motors connected to the drive FIXED BOOST level set too high
4	HEATSINK A HDT	<i>Drive heatsink temperature > 100°C:</i> <ul style="list-style-type: none"> The ambient air temperature is too high Poor ventilation or spacing between drives
5	EXTERNAL TRIP A ET	<i>The external trip input is high:</i> <ul style="list-style-type: none"> Check configuration to identify the source of the signal (non-standard configuration)
6	INVERSE TIME A IT	<i>A prolonged overload condition, exceeding the Inverse Time allowance, has caused the trip:</i> <ul style="list-style-type: none"> Remove the overload condition - refer to Chapter 5: P12
7	CURRENT LOOP A LOOP	<i>A current of less than 1mA is present when 4-20mA setpoint is selected:</i> <ul style="list-style-type: none"> Look for a wire break
8	MOTOR STALLED A SELL	<i>The motor has stalled (not rotating) Drive in current limit >200 seconds:</i> <ul style="list-style-type: none"> Motor loading too great FIXED BOOST level set too high
9	ANIN FAULT A E 3	<i>AIN2 overload on terminal 3:</i> <ul style="list-style-type: none"> Overcurrent applied in Current mode to terminal 3
10	BRAKE RESISTOR A db R	<i>External dynamic brake resistor has been overloaded:</i> <ul style="list-style-type: none"> Trying to decelerate a large inertia too quickly or too often
11	BRAKE SWITCH A db S	<i>Internal dynamic braking switch has been overloaded:</i> <ul style="list-style-type: none"> Trying to decelerate a large inertia too quickly or too often
12	DISPLAY/KEYPAD A DISP	<i>Keypad has been disconnected from drive whilst drive is running in Local Control:</i> <ul style="list-style-type: none"> Keypad accidentally disconnected from drive (indicated over Comms, or by second keypad)
13	LOST COMMS A SCI	<i>Lost communications:</i> <ul style="list-style-type: none"> COMMS TIMEOUT parameter set too short Master device failed Wiring broken Incorrect Comms setup

ID	Trip Name	Possible Reason for Trip
14	CONTACTOR FBK A C N E C	Contactor feedback signal lost: <ul style="list-style-type: none"> Check connection to the terminal wired to "contactor closed" parameter in Sequencing Logic (non-standard configuration)
15	SPEED FEEDBACK A S P d	Speed feedback: <ul style="list-style-type: none"> SPEED ERROR > 50.00% for 10 seconds
17	MOTOR OVERTEMP A O t	The motor temperature is too high: <ul style="list-style-type: none"> Excessive load Motor voltage rating incorrect FIXED BOOST level set too high Prolonged operation of the motor at low speed without forced cooling Break in motor thermistor connection
18	CURRENT LIMIT A I H I	Software overcurrent trip: <ul style="list-style-type: none"> If the current exceeds 180% of stack rated current for a period of 1 second, the drive will trip. This is caused by shock loads. Remove the shock load. ACCEL TIME and/or FIXED BOOST set too high DECEL TIME set too low
21	LOW SPEED OVER I A L S P d	The motor is drawing too much current (>100%) at zero output frequency: <ul style="list-style-type: none"> FIXED BOOST level set too high
22	10V FAULT A t 4	10V fault: <ul style="list-style-type: none"> +10V REF overload warning (terminal 4) - 10mA maximum
25	DC LINK RIPPLE A D C L R P	The dc link ripple voltage is too high: <ul style="list-style-type: none"> Check for a missing input phase
27	OVERSPEED A O S P d	Overspeed: <ul style="list-style-type: none"> >150% base speed when in Sensorless Vector mode
28	ANOUT FAULT A t 5	AOUT overload on terminal 5: <ul style="list-style-type: none"> 10mA maximum
29	DIGIO 1 (T9) FAULT A t 9	DIN3 overload on terminal 9: <ul style="list-style-type: none"> 20mA maximum
30	DIGIO 2 (T10) FAULT A t 10	DOUT2 overload on terminal 10: <ul style="list-style-type: none"> 50mA maximum
31	UNKNOWN A t I P	Unknown trip
32	OTHER A t 32	"OTHER" trip is active (Trip ID 34 to 44 inclusive)
34	MAX SPEED LOW A t N 1	During Autotune the motor is required to run at the nameplate speed of the motor. If MAX SPEED RPM limits the speed to less than this value, an error will be reported. Increase the value of MAX SPEED RPM up to the nameplate rpm of the motor (as a minimum). It may be reduced, if required, after the Autotune is complete.

7-4 Trips and Fault Finding

ID	Trip Name	Possible Reason for Trip
35	MAIN VOLTS LOW AEN2	The mains input voltage is not sufficient to carry out the Autotune. Re-try when the mains has recovered.
36	NOT AT SPEED AEN3	The motor was unable to reach the required speed to carry out the Autotune. Possible reasons include: <ul style="list-style-type: none"> motor shaft not free to turn the motor data is incorrect
37	MAG CURRENT FAIL AEN4	It was not possible to find a suitable value of magnetising current to achieve the required operating condition for the motor. Check the motor data is correct, especially nameplate rpm and motor volts. Also check that the motor is correctly rated for the drive.
38	NEGATIVE SLIP F AEN5	Autotune has calculated a negative slip frequency, which is not valid. Nameplate rpm may have been set to a value higher than the base speed of the motor. Check nameplate rpm, base frequency, and pole pairs are correct.
39	TR TOO LARGE AEN6	The calculated value of rotor time constant is too large. Check the value of nameplate rpm.
40	TR TOO SMALL AEN7	The calculated value of rotor time constant is too small. Check the value of nameplate rpm.
41	MAX RPM DATA ERR AEN8	This error is reported when the MAX SPEED RPM is set to a value outside the range for which Autotune has gathered data. Autotune gathers data on the motor characteristics up to 30% beyond "max speed rpm". If MAX SPEED RPM is later increased beyond this range, the drive had no data for this new operating area, and so will report an error. To run the motor beyond this point it is necessary to re-autotune with MAX SPEED RPM set to a higher value.
42	LEAKGE L TIMEOUT AEN9	The motor must be stationary when starting the Autotune
43	MOTOR TURNING ERR AENA	The motor must be able to rotate during Autotune
44	MOTOR STALL ERR AENB	The leakage inductance measurement requires a test current to be inserted into the motor. It has not been possible to achieve the required level of current. Check that the motor is wired correctly.
-	Product Code Error ACDE	Switch unit off/on. If persistent, return unit to factory
-	Calibration Data Error ACAL	Switch unit off/on. If persistent, return unit to factory
-	Configuration Data Error ADAE	Press the E key to accept the default configuration. If persistent, return unit to factory

Hexadecimal Representation of Trips

The tables below show the possible parameter values for the AUTO RESTART TRIGGERS and AUTO RESTART TRIGGERS+ parameters, ^SST23 and ^SST24 respectively. Refer to the 650V Software Product Manual, "Trips Status" (on our website: www.SSDdrives.com) for additional trip information that is available over the Comms.

Each trip has a unique, four-digit hexadecimal number number as shown in the tables below.

^S ST23 : AUTO RESTART TRIGGERS				
ID	Trip Name (MMI 6901)	Trip Name (MMI 6511 & 6521)	Mask	User Disable
1	OVERVOLTAGE	DCHI	0x0001	
2	UNDERVOLTAGE	DCLO	0x0002	
3	OVERCURRENT	OC	0x0004	
4	HEATSINK	HOT	0x0008	
5	EXTERNAL TRIP	ET	0x0010	✓
6	INVERSE TIME	51 t	0x0020	✓
7	CURRENT LOOP	5LOOP	0x0040	✓
8	MOTOR STALLED	5StLL	0x0080	✓
9	ANIN FAULT	5 t 3	0x0100	✓
10	BRAKE RESISTOR	5db f	0x0200	✓
11	BRAKE SWITCH	5db S	0x0400	✓
12	DISPLAY/KEYPAD	5dl SP	0x0800	✓
13	LOST COMMS	SCI	0x1000	✓
14	CONTACTOR FBK	CNTC	0x2000	✓
15	SPEED FEEDBACK	5SPd	0x4000	✓

^S ST24 : AUTO RESTART TRIGGERS+				
ID	Trip Name (MMI 6901)	Trip Name (MMI 6511 & 6521)	Mask +	User Disable
17	MOTOR OVERTEMP	50t	0x0001	✓
18	CURRENT LIMIT	I HI	0x0002	
21	LOW SPEED OVER I	LSPD	0x0010	
22	10V FAULT	T 4	0x0020	✓
25	DC LINK RIPPLE	DCRP	0x0100	✓
27	OVERSPEED	5OSPd	0x0400	✓
28	ANOUT FAULT	T 5	0x0800	✓
29	DIGIO 1 (T9) FAULT	T 9	0x1000	✓
30	DIGIO 2 (T10) FAULT	T 10	0x2000	✓
31	UNKNOWN	TRIP	0x4000	
32	OTHER	TR32	0x8000	
34	MAX SPEED LOW	ATN1	0x8000	N/A
35	MAIN VOLTS LOW	ATN2	0x8000	N/A
36	NOT AT SPEED	ATN3	0x8000	N/A
37	MAG CURRENT FAIL	ATN4	0x8000	N/A
38	NEGATIVE SLIP F	ATN5	0x8000	N/A
39	TR TOO LARGE	ATN6	0x8000	N/A
40	TR TOO SMALL	ATN7	0x8000	N/A
41	MAX RPM DATA ERR	ATN8	0x8000	N/A
42	LEAKGE L TIMEOUT	ATN9	0x8000	N/A

7-6 Trips and Fault Finding

ST24 : AUTO RESTART TRIGGERS+				
ID	Trip Name (MMI 6901)	Trip Name (MMI 6511 & 6521)	Mask +	User Disable
43	MOTOR TURNING ERR	ATNA	0x8000	N/A
44	MOTOR STALL ERR	ATNB	0x8000	N/A

Keypads (MMIs):

Trips shown as MMI displays in the tables above, i.e. **5LOOP**, can be disabled using the keypads in the TRIPS menu. Other trips, as indicated, can be disabled over the Comms.



6901



6511



6521

Hexadecimal Representation of Trips

When more than one trip is to be represented at the same time then the trip codes are simply added together to form the value displayed. Within each digit, values between 10 and 15 are displayed as letters A to F

Decimal number	Display
10	A
11	B
12	C
13	D
14	E
15	F

For example referring to the tables above, if the AUTO RESTART TRIGGERS parameter is set to **04A0**, then this represents:

a "4" in digit 3

an "8" and a "2" in digit 2
(8+2 = 10, displayed as A)

an "0" in digit 1

This in turn represents the trips BRAKE SWITCH, ANIN FAULT, MOTOR STALLED and INVERSE TIME.

In the same way, the AUTO RESTART TRIGGERS+ parameter set to **04A0** would represent OVERSPEED, ANIN FAULT, DESAT OVER I and 10V FAULT.

Fault Finding

Problem	Possible Cause	Remedy
Drive will not power-up	Fuse blown	Check supply details, fit correct fuse.
	Faulty cabling	Check Product Code against Model No. Check all connections are correct/secure. Check cable continuity
Drive fuse keeps blowing	Faulty cabling or connections wrong	Check for problem and rectify before replacing with correct fuse
	Faulty drive	Contact SSD Drives
Cannot obtain power-on state	Incorrect or no supply available	Check supply details
Motor will not run at switch-on	Motor jammed	Stop the drive and clear the jam
Motor runs and stops	Motor becomes jammed	Stop the drive and clear the jam
	Open circuit speed reference potentiometer	Check terminal

ROUTINE MAINTENANCE AND REPAIR

Routine Maintenance

Periodically inspect the drive for build-up of dust or obstructions that may affect ventilation of the unit. Remove this using dry air.

Repair

There are no user-serviceable components.

IMPORTANT: MAKE NO ATTEMPT TO REPAIR THE UNIT - RETURN IT TO SSD DRIVES.

Saving Your Application Data

In the event of a repair, application data will be saved whenever possible. However, we advise you to copy your application settings before returning the unit.

Returning the Unit to SSD Drives

Please have the following information available:

- The model and serial number - see the unit's rating label
- Details of the fault

Contact your nearest SSD Drives Service Centre to arrange return of the item.

You will be given a *Returned Material Authorisation*. Use this as a reference on all paperwork you return with the faulty item. Pack and despatch the item in the original packing materials; or at least an anti-static enclosure. Do not allow packaging chips to enter the unit.

Disposal

This product contains materials which are consignable waste under the Special Waste Regulations 1996 which complies with the EC Hazardous Waste Directive - Directive 91/689/EEC.

We recommend you dispose of the appropriate materials in accordance with the valid environmental control laws. The following table shows which materials can be recycled and which have to be disposed of in a special way.

Material	Recycle	Disposal
metal	yes	no
plastics material	yes	no
printed circuit board	no	yes

The printed circuit board should be disposed of in one of two ways:

1. High temperature incineration (minimum temperature 1200°C) by an incinerator authorised under parts A or B of the Environmental Protection Act
2. Disposal in an engineered land fill site that is licensed to take aluminium electrolytic capacitors. Do not dispose of in a land fill site set aside for domestic waste.

Packaging

During transport our products are protected by suitable packaging. This is entirely environmentally compatible and should be taken for central disposal as secondary raw material.

Technical Specifications

Understanding the Product Code

Model Number (Europe)

The unit is fully identified using a nine block alphanumeric code which records how the drive was calibrated, and its various settings when despatched from the factory.

The Product Code appears as the “Model No.” on the product rating label. Each block of the Product Code is identified as below:

650V/003/230/F/00/DISP/UK/RSO/0
Block 1 2 3 4 5 6 7 8 9
example product code

Frame 1, 2, 3 – Model Number (Europe)		
Block No.	Variable	Description
1	650V	Generic Volts/Hertz product
2	XXX	Three numbers specifying the power output: 002 = 0.25kW 011 = 1.1kW 040 = 4.0kW 003 = 0.37kW 015 = 1.5kW 055 = 5.5kW 005 = 0.55kW 022 = 2.2kW 075 = 7.5kW 007 = 0.75kW 030 = 3.0kW
3	XXX	Three numbers specifying the nominal input voltage rating: 230 = 220 to 240V (±10%) 50/60Hz 400 = 380 to 460V (±10%) 50/60Hz
4	X	One character specifying the use of the Internal RFI Filter: 0 = Not fitted F = Internal Supply Filter fitted: Class A - 400V product Class B - 230V product
5	XX	Two digits specifying the livery: 00 = Standard SSD Drives Livery 05 = Distributor Livery (01-04, 06-99 – Defined customer liveries)
6	XXXXX	Characters specifying the use of the Keypad: 0 = Not fitted DISP = Standard Keypad DISPR = Remote Keypad fitted (RS232) Block 8 must = RSO with this selection
7	XX	Two Characters specifying the user labelling language: FR French (50Hz) UK English (50Hz) GR German (50Hz) US English (60Hz) IT Italian (50Hz) SP Spanish (50Hz) (figures in brackets are the drive’s default base frequency setting, ^{P7})

Frame 1, 2, 3 – Model Number (Europe)		
Block No.	Variable	Description
8	XXX	Characters specifying the RS232 (P3) port fitting: RS0 = RS232 port (for use by Remote Keypad)
9	XXX	Numbers specifying any special option: 0 = Standard Product 001-999 = special option fitted

Catalog Number (North America)

The unit is identified using a 4 block alphanumeric code which records how the drive was calibrated, and its various settings when dispatched from the factory. All drives are in Standard SSD Drives Livery and operate on 50/60Hz..

The Product Code appears as the “Cat No.”. Each block of the Product Code is identified as below:

650V/00F3/230/SNF
Block 1 2 3 4
example product code

Frame 1, 2, 3 – Catalog Number (North America)		
Block No.	Variable	Description
1	650V	Generic product
2	XXXX	Four characters specifying the power output in Hp: 00F3 = 0.3Hp 01F5 = 1.5Hp 0005 = 5Hp 00F5 = 0.5Hp 0002 = 2Hp 0007 = 7Hp 00F7 = 0.75Hp 0003 = 3Hp 0010 = 10Hp 0001 = 1Hp
3	XXX	Three numbers specifying the nominal input voltage rating: 230 230 (±10%) 50/60Hz 460 380 to 460V (±10%) 50/60Hz
4	X	One character specifying the use of the Keypad: S = Standard Keypad fitted R = Remote Keypad fitted
	X	Indicates if the drive is fitted with the Brake Switch N = Brake switch not fitted (230V Frames 1 & 2) B = Brake switch fitted (460V Frames 2 & 3)
	X	One character specifying the use of the Internal RFI Filter: N = Not fitted F = Internal Supply Filter fitted

9-3 Technical Specifications

Environmental Details	
Operating Temperature	0°C to 40°C
Storage Temperature	-25°C to +55°C
Shipping Temperature	-25°C to +70°C
Product Enclosure Rating	IP20 (UL Open Type) suitable for cubicle mount only
Cubicle Rating	Cubicle to provide 15dB attenuation to radiated emissions between 30-100MHz. It must also require a security tool for opening
Altitude	If > 1000 metres (3300 feet) above sea level, derate Motor Power Rating by 1% per 100 metres (330 feet)
Humidity	Maximum 85% relative humidity at 40°C non-condensing
Atmosphere	Non flammable, non corrosive and dust free
Climatic Conditions	Class 3k3, as defined by EN50178 (1998)
Vibration	Test Fc of EN60068-2-6 10Hz<=f<=57Hz sinusoidal 0.075mm amplitude 57Hz<=f<=150Hz sinusoidal 1g 10 sweep cycles per axis on each of three mutually perpendicular axis
Safety	
Pollution Degree	Pollution Degree II (non-conductive pollution, except for temporary condensation)
Overvoltage Category	Overvoltage Category III (numeral defining an impulse withstand level)

Power Details	
1-Phase Supply	220-240V ac ±10%,50/60Hz ±10%, ground referenced (TN) or non-ground referenced (IT)
3-Phase Supply	220-240V ac or 380-460V ac ±10%,50/60Hz ±10%, ground referenced (TN) or non-ground referenced (IT)
Supply Power Factor (lag)	0.9 (@ 50/60Hz)
Output Frequency	0 – 240Hz
Overload	150% for 30 seconds
Supply Short Circuit Rating	220-240V 1φ product -5000A, 220-240V ac 3φ product - 7500A 380-460V 3φ product -10000A

Electrical Ratings

Motor power, output current and input current must not be exceeded under steady state operating conditions.

Maximum Motor $dv/dt = 10,000V/\mu s$. This can be reduced by adding a motor choke in series with the motor. Contact SSD Drives for recommended choke details.

Local wiring regulations always take precedence. Select cable rated for the drive.

The supply must be protected with a fuse (or Type B RCD) rated to the supply cable.

FRAME 1 : 1-Phase (IT/TN), 230V

Drive Power (kW/hp)	Input Current @ 5kA		Output Current @ 40 °C (A) ac	Maximum Power Loss (W)
	Surge Current peak/rms for 10ms (A)	(A)		
0.25/0.3	19/12	4.2	1.5	26
0.37/0.5	19/12	6.2	2.2	32
0.55/0.75	20/14	7.9	3.0	41
0.75/1.0	22/15	10.5	4.0	52

FRAME 2 : 1-Phase (IT/TN), 230V

Drive Power (kW/hp)	Input Current @ 5kA		Output Current @ 40 °C (A) ac	Maximum Power Loss (W)
	Surge Current peak/rms for 10ms (A)	(A)		
1.1/1.5	24/17	13.8	5.5	65
1.5/2.0	25/18	16.0	7.0	82

FRAME 2 : 3-Phase (IT/TN), 400V

Drive Power (kW/hp)	Input Current @ 10kA (A)	Output Current @ 40 °C (A) ac	Maximum Power Loss (W)
0.37/0.5	2.5	1.5	26
0.55/0.75	3.3	2.0	32
0.75/1.0	4.1	2.5	40
1.1/1.5	5.9	3.5	55
1.5/2.0	7.5	4.5	61
2.2/3.0	9.4	5.5	70

FRAME 3 : 3-Phase (IT/TN), 230V

Drive Power (kW/hp)	Input Current @ 7.5kA (A)	Output Current @ 40 °C (A) ac	Maximum Power Loss (W)
2.2/3.0	14.6	9.6	103
3.0/4.0	18.8	12.3	133
4.0/5.0	24.0	16.4	180

FRAME 3 : 3-Phase (IT/TN), 400V

Drive Power (kW/hp)	Input Current @ 10kA (A)	Output Current @ 40 °C (A) ac	Maximum Power Loss (W)
3.0/4.0	11.1	6.8	80
4.0/5.0	13.9	9.0	100
5.5/7.5	18.0	12.0	136
7.5/10.0	23.6	16.0	180

9-5 Technical Specifications

User Relay	
RL1A, RL1B.	
Maximum Voltage	250Vac
Maximum Current	4A
Sample Interval	10ms

Analog Inputs/Outputs		
AIN1, AIN2, AOUT.		
	Inputs	Output
Range	0-10V and 0-5V (no sign) set via parameter ⁹ IP13 (AIN1) 0-10V, 0-5V, 0-20mA or 4-20mA (no sign) set via parameter ⁹ IP23 (AIN2) Absolute maximum input current 25mA in current mode Absolute maximum input voltage 24V dc in voltage mode	0-10V (no sign) Maximum rated output current 10mA, with short circuit protection
Impedance	Voltage input 20kΩ Current Input <6V @ 20mA	
Resolution	10 bits (1 in 1024)	10 bits (1 in 1024)
Dynamic Response	Sampled every 10ms	Bandwidth 15Hz

Digital Inputs		
Operating Range	DIN1, DIN2, DIN3, DIN4, DIN5: 0-5V dc = OFF, 15-24V dc = ON (absolute maximum input voltage ±30V dc) IEC1131 DIN6, DIN7: 0-1.5V dc = OFF, 4-24V dc = ON (absolute maximum input voltage ±30V dc) IEC1131	
Input Current	7.5mA @ 24V	
Sample Interval	10ms	

Digital Outputs	
DOUT1 and DOUT2 (DOUT1 is only configurable using ConfigEd Lite or other suitable programming tool).	
Nominal Open Circuit Output Voltage	23V (minimum 19V)
Nominal Output Impedance	33Ω
Rated Output Current	50mA

Cabling Requirements for EMC Compliance				
	Power Supply Cable	Motor Cable	Brake Resistor Cable	Signal/Control Cable
Cable Type (for EMC Compliance)	Unscreened	Screened/armoured	Screened/armoured	Screened
Segregation	From all other wiring (clean)	From all other wiring (noisy)		From all other wiring (sensitive)
Length Limitations With Internal AC Supply EMC Filter	Unlimited	*25 metres	25 metres	25 metres
Length Limitations Without Internal AC Supply EMC Filter	Unlimited	25 metres	25 metres	25 metres
Screen to Earth Connection		Both ends	Both ends	Drive end only
Output Choke		300 metres maximum		

* Maximum motor cable length under any circumstances

Internal Dynamic Braking Circuit				
The dynamic braking circuit is intended for with short term stopping or braking.				
Motor Power (kW/Hp)	Brake Switch Peak Current (A)	Brake Switch Continuous Current (A)	Peak Brake Dissipation (kW/Hp)	Minimum Brake Resistor Value (Ω)
Frame 2 : 3 Phase (IT/TN), 400V, 100% duty DC link brake voltage : 750V				
0.37/0.5	1.5	1.5	1.1/1.5	500
0.55/0.75	1.5	1.5	1.1/1.5	500
0.75/1.0	1.5	1.5	1.1/1.5	500
1.1/1.5	1.5	1.5	1.1/1.5	500
1.5/2.0	3.75	3.75	2.8/3.75	200
2.2/3.0	3.75	3.75	2.8/3.75	200
Frame 3 : 3 Phase (IT/TN), 230V, 100% duty DC link brake voltage : 390V				
2.2/3.0	7.0	7.0	2.72	56
3.0/4	10.8	10.8	4.23	36
4.0/5	14.0	14.0	5.44	28
Frame 3 : 3 Phase (IT/TN), 400V, 30% duty DC link brake voltage : 750V				
3.0/4	7.5	2.3	5.6/7.5	100
4.0/5	7.5	2.3	5.6/7.5	100
5.5/7.5	13.5	4.0	10/13.4	56
7.5/10	13.5	4.0	10/13.4	56

Supply Harmonic Analysis (230V filtered)

Assumptions: (Short circuit fault to Neutral)
 5kA short circuit supply capability at 230V 1ϕ, equivalent to 146μH supply impedance
 7.5kA short circuit supply capability at 230V 3ϕ, equivalent to 56μH supply impedance
 10kA short circuit supply capability at 400V 3ϕ, equivalent to 73μH supply impedance

$$THD(V) \times 100 = \frac{\sqrt{\sum_{h=2}^{h=40} Q_h^2}}{Q_{1n}} \%$$

where Q_{1n} is the rated rms value of the fundamental voltage of the supply transformer.

The results conform to stage 1 and stage 2 of the Engineering Recommendation G.5/4 February 2001, Classification 'C': Limits for Harmonics in the UK Electricity Industry.

Drive Type	650V								
Motor Power (kW)	0.25	0.37	0.55	0.75	1.1	1.5	2.2	3.0	4.0
Fundamental Voltage (V)	230	230	230	230	230	230	230	230	230
Typical Motor Efficiency %	85	85	85	85	85	85	85	85	85
Harmonic No.	RMS Current (A)								
1	7.4	7.5	7.8	8.2	9.0	10.3	TBA	TBA	TBA
3	1.4	0.2	1.9	2.2	2.9	3.9			
5	2.9	0.4	4.4	4.6	4.8	5.2			
7	1.1	0.5	1.9	2.0	2.3	2.5			
9	0.2	0.2	0.2	0.3	0.4	0.4			
11	0.1	0.1	0.2	0.2	0.2	0.3			
13	0.0	0.1	0.1	0.1	0.1	0.1			
15	0.1	0.0	0.1	0.1	0.1	0.1			
17	0.0	0.1	0.0	0.0	0.0	0.1			
19	0.0	0.0	0.0	0.0	0.0	0.1			
21	0.0	0.0	0.0	0.0	0.0	0.1			
23	0.0	0.0	0.0	0.0	0.0	0.0			
25	0.0	0.0	0.0	0.0	0.0	0.0			
27	0.0	0.0	0.0	0.0	0.0	0.0			
29	0.0	0.0	0.0	0.0	0.0	0.0			
31	0.0	0.0	0.0	0.0	0.0	0.0			
33	0.0	0.0	0.0	0.0	0.0	0.0			
35	0.0	0.0	0.0	0.0	0.0	0.0			
37	0.0	0.0	0.0	0.0	0.0	0.0			
39	0.0	0.0	0.0	0.0	0.0	0.0			
40	0.0	0.0	0.0	0.0	0.0	0.0			
Total RMS Current (A)	8.2	7.5	9.3	9.9	10.9	12.5			
THD (V) %	0.3559	0.0972	0.5426	0.5733	0.6277	0.7055			

9-9 Technical Specifications

Supply Harmonic Analysis (400V filtered)

Assumptions: (Short circuit fault to Neutral)

5kA short circuit supply capability at 230V 1 ϕ , equivalent to 146 μ H supply impedance

7.5kA short circuit supply capability at 230V 3 ϕ , equivalent to 56 μ H supply impedance

10kA short circuit supply capability at 400V 3 ϕ , equivalent to 73 μ H supply impedance

$$THD(V) \times 100 = \frac{\sqrt{\sum_{h=2}^{h=40} Q_h^2}}{Q_{1n}} \%$$

where Q_{1n} is the rated rms value of the fundamental voltage of the supply transformer.

The results conform to stage 1 and stage 2 of the Engineering Recommendation G.5/4 February 2001, Classification 'C': Limits for Harmonics in the UK Electricity Industry.

Drive Type	650V									
Motor Power (kW)	0.37	0.55	0.75	1.1	1.5	2.2	3.0	4.0	5.5	7.5
Fundamental Voltage (V)	400	400	400	400	400	400	400	400	400	400
Typical Motor Efficiency %	85	85	85	85	85	85	85	85	85	85
Harmonic No.	RMS Current (A)									
1	0.6	1.0	1.3	1.9	2.6	3.8	5.2	6.9	9.5	12.9
3	0.0	0.0	0.0	0.0	0.0	0.0	0.0	0.0	0.0	0.0
5	0.6	0.9	1.2	1.8	2.4	3.5	4.7	6.2	8.3	11.1
7	0.6	0.9	1.2	1.7	2.3	3.3	4.3	5.5	7.3	9.5
9	0.0	0.0	0.0	0.0	0.0	0.0	0.0	0.0	0.0	0.0
11	0.5	0.8	1.0	1.5	1.9	2.6	3.3	3.9	4.8	5.7
13	0.0	0.7	0.9	1.3	1.6	2.2	2.7	3.0	3.5	3.9
15	0.4	0.0	0.0	0.0	0.0	0.0	0.0	0.0	0.0	0.0
17	0.4	0.6	0.7	1.0	1.1	1.4	1.6	1.5	1.4	1.2
19	0.0	0.5	0.6	0.9	0.9	1.1	1.1	0.9	0.8	0.7
21	0.3	0.0	0.0	0.0	0.0	0.0	0.0	0.0	0.0	0.0
23	0.2	0.3	0.4	0.6	0.5	0.5	0.4	0.3	0.5	0.7
25	0.0	0.3	0.3	0.4	0.3	0.3	0.2	0.4	0.5	0.7
27	0.1	0.0	0.0	0.0	0.0	0.0	0.0	0.0	0.0	0.0
29	0.1	0.2	0.2	0.2	0.1	0.2	0.3	0.4	0.4	0.4
31	0.0	0.1	0.1	0.1	0.1	0.2	0.3	0.3	0.3	0.3
33	0.1	0.0	0.0	0.0	0.0	0.0	0.0	0.0	0.0	0.0
35	0.0	0.1	0.1	0.1	0.1	0.2	0.2	0.2	0.2	0.3
37	0.0	0.1	0.1	0.1	0.1	0.2	0.1	0.1	0.2	0.3
39	0.0	0.0	0.0	0.0	0.0	0.0	0.0	0.0	0.0	0.0
40	0.0	0.0	0.0	0.0	0.0	0.0	0.0	0.0	0.0	0.0
Total RMS Current (A)	1.4	2.1	2.8	4.0	5.1	7.2	9.5	12.0	15.8	20.8
THD (V) %	0.1561	0.2158	0.2776	0.3859	0.4393	0.5745	0.6994	0.8111	0.9899	1.2110

Supply Harmonic Analysis (230V unfiltered)

Assumptions: (Short circuit fault to Neutral)

5kA short circuit supply capability at 230V 1φ, equivalent to 146μH supply impedance

7.5kA short circuit supply capability at 230V 3φ, equivalent to 56μH supply impedance

10kA short circuit supply capability at 400V 3φ, equivalent to 73μH supply impedance

$$THD(V) \times 100 = \frac{\sqrt{\sum_{h=2}^{h=40} Q_h^2}}{Q_{1n}} \%$$

where Q_{1n} is the rated rms value of the fundamental voltage of the supply transformer.

The results conform to stage 1, stage 2 and stage 3 of the Engineering Recommendation G.5/3 September 1976, Classification 'C': Limits for Harmonics in the UK Electricity Industry.

Drive Type	650V								
Motor Power (kW)	0.25	0.37	0.55	0.75	1.1	1.5	2.2	3.0	4.0
Fundamental Voltage (V)	230	230	230	230	230	230	230	230	230
Typical Motor Efficiency %	85	85	85	85	85	85	85	85	85
Harmonic No.	RMS Current (A)								
1	1.3	2.0	2.9	3.9	5.7	7.8	TBA	TBA	TBA
3	1.3	1.9	2.9	3.8	5.5	7.4			
5	1.2	1.9	2.7	3.5	5.0	6.7			
7	1.1	1.7	2.5	3.1	4.4	5.4			
9	1.1	1.6	2.2	2.7	3.7	4.6			
11	1.0	1.4	1.9	2.2	2.9	3.4			
13	0.8	1.2	1.6	1.6	2.1	2.3			
15	0.7	1.0	1.3	1.2	1.4	1.4			
17	0.6	0.8	1.0	0.8	0.8	0.7			
19	0.5	0.7	0.7	0.4	0.4	0.3			
21	0.4	0.5	0.5	0.2	0.2	0.4			
23	0.3	0.3	0.3	0.2	0.3	0.4			
25	0.2	0.2	0.1	0.2	0.3	0.4			
27	0.1	0.1	0.1	0.2	0.3	0.3			
29	0.1	0.1	0.1	0.2	0.2	0.2			
31	0.0	0.1	0.1	0.1	0.1	0.1			
33	0.0	0.1	0.1	0.1	0.1	0.2			
35	0.0	0.1	0.1	0.1	0.1	0.2			
37	0.1	0.1	0.1	0.1	0.1	0.1			
39	0.0	0.1	0.1	0.1	0.1	0.1			
40	0.0	0.0	0.0	0.0	0.0	0.0			
Total RMS Current (A)	3.2	4.8	6.7	8.3	11.7	15.3			
THD (V) %	0.5633	0.8016	1.0340	1.0944	1.4611	1.7778			

9-11 Technical Specifications

Supply Harmonic Analysis (400V unfiltered)

Assumptions: (Short circuit fault to Neutral)

5kA short circuit supply capability at 230V 1 ϕ , equivalent to 146 μ H supply impedance

7.5kA short circuit supply capability at 230V 3 ϕ , equivalent to 56 μ H supply impedance

10kA short circuit supply capability at 400V 3 ϕ , equivalent to 73 μ H supply impedance

$$THD(V) \times 100 = \frac{\sqrt{\sum_{h=2}^{h=40} Q_h^2}}{Q_{1n}} \%$$

where Q_{1n} is the rated rms value of the fundamental voltage of the supply transformer.

The results conform to stage 1, stage 2 and stage 3 of the Engineering Recommendation G.5/3 September 1976, Classification 'C': Limits for Harmonics in the UK Electricity Industry.

Drive Type	650V									
Motor Power (kW)	0.37	0.55	0.75	1.1	1.5	2.2	3.0	4.0	5.5	7.5
Fundamental Voltage (V)	400	400	400	400	400	400	400	400	400	400
Typical Motor Efficiency %	85	85	85	85	85	85	85	85	85	85
Harmonic No.	RMS Current (A)									
1	0.6	0.9	1.3	1.9	2.6	3.8	5.2	6.9	9.5	12.7
3	0.0	0.0	0.0	0.0	0.0	0.0	0.0	0.0	0.0	0.0
5	0.6	0.9	1.2	1.8	2.4	3.6	4.7	6.3	8.4	11.0
7	0.6	0.9	1.2	1.7	2.3	3.3	4.3	5.7	7.4	9.5
9	0.0	0.0	0.0	0.0	0.0	0.0	0.0	0.0	0.0	0.0
11	0.5	0.8	1.0	1.5	1.9	2.6	3.3	4.2	4.9	5.8
13	0.5	0.7	0.9	1.3	1.6	2.2	2.7	3.4	3.7	4.0
15	0.0	0.0	0.0	0.0	0.0	0.0	0.0	0.0	0.0	0.0
17	0.4	0.6	0.7	0.9	1.2	1.5	1.6	1.9	1.5	1.3
19	0.4	0.5	0.6	0.8	0.9	1.1	1.1	1.3	0.8	0.7
21	0.0	0.0	0.0	0.0	0.0	0.0	0.0	0.0	0.0	0.0
23	0.3	0.4	0.4	0.5	0.5	0.5	0.4	0.4	0.5	0.7
25	0.2	0.3	0.3	0.3	0.4	0.3	0.2	0.3	0.5	0.7
27	0.0	0.0	0.0	0.0	0.0	0.0	0.0	0.0	0.0	0.0
29	0.1	0.2	0.2	0.2	0.1	0.2	0.2	0.3	0.4	0.4
31	0.1	0.1	0.1	0.1	0.1	0.2	0.3	0.3	0.3	0.3
33	0.0	0.0	0.0	0.0	0.0	0.0	0.0	0.0	0.0	0.0
35	0.1	0.1	0.1	0.1	0.1	0.2	0.2	0.2	0.2	0.3
37	0.0	0.1	0.1	0.1	0.1	0.2	0.2	0.1	0.2	0.2
39	0.0	0.0	0.0	0.0	0.0	0.0	0.0	0.0	0.0	0.0
40	0.0	0.0	0.0	0.0	0.0	0.0	0.0	0.0	0.0	0.0
Total RMS Current (A)	1.5	2.1	2.8	4.0	5.1	7.4	9.5	12.4	16.0	20.6
THD (V) %	0.1634	0.2209	0.2817	0.3569	0.4444	0.5886	0.7107	0.8896	1.0127	1.2138

CERTIFICATION FOR THE DRIVE

Requirements for EMC Compliance

Earthing Requirements

IMPORTANT: Protective earthing always takes precedence over EMC earthing.

Protective Earth (PE) Connections

Note: *In accordance with installations to EN60204, only one protective earth conductor is permitted at each protective earth terminal contacting point.*

Local wiring regulations may require the protective earth connection of the motor to be connected locally, i.e. not as specified in these instructions. This will not cause shielding problems because of the relatively high RF impedance of the local earth connection.

EMC Earth Connections

For compliance with EMC requirements, the “0V/signal ground” is to be separately earthed. When a number of units are used in a system, these terminals should be connected together at a single, local earthing point.

Control and signal cables connections should be made with screened cables, with the screen connected only at the VSD end. However, if high frequency noise is still a problem, earth screen at the non VSD end via a 0.1µF capacitor.

Note: *Connect the screen (at the VSD end) to the VSD protective earth point, and not to the control board terminals.*

Requirements for UL Compliance

Solid-State Motor Overload Protection

These devices provide Class 10 motor overload protection. The maximum internal overload protection level (current limit) is 150% for 30 seconds.

An external motor overload protective device must be provided by the installer where the motor has a full-load ampere rating of less than 50% of the drive output rating; or when the DISABLE STALL trip (^SSTLL) is set to True (1); or when the STALL TIME parameter is increased above 480 seconds (refer to the 650V Software Manual, Chapter 1 : STALL TRIP).

Short Circuit Rating

The following drives are suitable for use on a circuit capable of delivering not more than:

220-240V product, 1φ - 5000 RMS Symmetrical Amperes

220-240V product, 3φ - 7500 RMS Symmetrical Amperes

380-460V product, 3φ - 10000 RMS Symmetrical Amperes

Solid-State Short-Circuit Protection

These devices are provided with Solid-State Short-Circuit (output) Protection. Branch circuit protection requirements must be in accordance with the latest edition of the National Electrical Code NEC/NFPA-70.

Recommended Branch Circuit Protection

It is recommended that UL Listed (JDDZ) non-renewable cartridge fuses, Class K5 or H; or UL Listed (JDRX) renewable cartridge fuses, Class H, are installed upstream of the drive.

Motor Base Frequency

The motor base frequency rating is 240Hz maximum.

Field Wiring Temperature Rating

Use 75°C Copper conductors only.

10-2 Certification for the Drive

Field Wiring Terminal Markings

For correct field wiring connections that are to be made to each terminal refer to Chapter 3: “Installing the Drive” - Wiring Guidelines.

Terminal Tightening Torque

Refer to Chapter 3: “Installing the Drive” – Terminal Tightening Torque.

Terminal/Wire Sizes

North American wire sizes (AWG) are based on NEC/NFPA-70 for ampacities of thermoplastic-insulated (75°C) copper conductors.

Power input and output wire sizes should allow for an ampacity of 125% of the rated input and output amperes for motor branch-circuit conductors as specified in NEC/NFPA-70. Refer to Chapter 3: “Installing the Drive” – Terminal Block Acceptance Sizes.

Input Fuse Ratings

If fitted, fuses should be in accordance with NEC/NFPA-70.

FRAME 1 : 1-Phase (IT/TN), 230V		
Drive Power (kW/hp)	Input Current @ 5kA	Supply Fuse Rating (A) 10 x 38mm
	(A)	
0.25/0.3	4.2	10
0.37/0.5	6.2	10
0.55/0.75	7.9	10
0.75/1.0	10.5	15
FRAME 2 : 1-Phase (IT/TN), 230V		
Drive Power (kW/hp)	Input Current @ 5kA	Supply Fuse Rating (A) 10 x 38mm
	(A)	
1.1/1.5	13.8	20
1.5/2.0	16.0	20
FRAME 2 : 3-Phase (IT/TN), 400V		
Drive Power (kW/hp)	Input Current @ 10kA	Supply Fuse Rating (A) 10 x 38mm
	(A)	
0.37/0.5	2.5	10
0.55/0.75	3.3	10
0.75/1.0	4.1	10
1.1/1.5	5.9	10
1.5/2.0	7.5	10
2.2/3.0	9.4	15
FRAME 3 : 3-Phase (IT/TN), 230V		
Drive Power (kW/hp)	Input Current @ 7.5kA	Supply Fuse Rating (A) 10 x 38mm
	(A)	
2.2/3.0	14.6	20
3.0/4.0	18.8	25
4.0/5.0	24.0	30
FRAME 3 : 3-Phase (IT/TN), 400V		
Drive Power (kW/hp)	Input Current @ 10kA	Supply Fuse Rating (A) 10 x 38mm
	(A)	
3.0/4	11.1	15
4.0/5	13.9	20
5.5/7.5	18.0	25
7.5/10	23.6	30

Field Grounding Terminals

The field grounding terminals are identified with the International Grounding Symbol (IEC Publication 417, Symbol 5019).



Operating Ambient Temperature

Devices are considered acceptable for use in a maximum ambient temperature of 40°C (can be derated up to 50°C).

European Directives and the CE Mark

CE Marking for Low Voltage Directive

When installed in accordance with this manual, the 650V AC Drive is CE marked by SSD Drives Ltd in accordance with the low voltage directive (S.I. No. 3260 implements this LVD directive into UK law). An EC Declaration of Conformity (low voltage directive) is included at the end of this chapter.

CE Marking for EMC - Who is Responsible?

Note: *The specified EMC emission and immunity performance of this unit can only be achieved when the unit is installed to the EMC Installation Instructions given in this manual.*

According to S.I. No. 2373 which implements the EMC directive into UK law, the requirement for CE marking this unit falls into two categories:

1. Where the supplied unit has an intrinsic/direct function to the end user, then the unit is classed as **relevant apparatus**. In this situation the responsibility for certification rests with SSD Drives. The Declaration of Conformity is included at the end of this Chapter.
2. Where the supplied unit is incorporated into a higher system/apparatus or machine which includes (at least) the motor, cable and a driven load but is unable to function without this unit, then the unit is classed as a **component**. In this circumstance, the responsibility rests with the manufacturer/supplier/installer of the system/apparatus/machine.

EMC Compliance

All Models All models are compliant with BS EN61800-3.	
Radiated Emissions	EN50081-1(1992) and EN61800-3 unrestricted distribution when mounted inside the specified cubicle, see above. Control and motor cables must be screened and correctly fitted with glands where they exit the cubicle. Control 0V must be connected to protective earth/ground.
Immunity	EN50082-1 (1997), EN61800-3 (1997), EN61000-6-2 (1999)
FRAME 1 & 2: 1-Phase (TN only),	
Conducted Emissions	EN50081-1(1992), EN61800-3 unrestricted distribution, maximum motor cable length: 25m
FRAME 2 & 3 : 3-Phase (TN only)	
Conducted Emissions	EN50081-2(1993), EN61800-3 restricted distribution maximum motor cable length: 25m

10-4 Certification for the Drive

Certificates

650V 0.25 - 4.0kW 230V



EC DECLARATIONS OF CONFORMITY

Date CE marked first applied: 26/07/2001

EMC Directive

In accordance with the EEC Directive 89/336/EEC and amended by 92/31/EEC and 93/68/EEC, Article 10 and Annex 1, (EMC DIRECTIVE)

We SSD Drives Limited, address as below, declare under our sole responsibility that the above Electronic Products when installed and operated with reference to the instructions in the Product Manual (provided with each piece of equipment) is in accordance with the relevant clauses from the following standard:-

BSEN61800-3 (1997)

Low Voltage Directive

In accordance with the EEC Directive 73/23/EEC and amended by 93/68/EEC, Article 13 and Annex III, (LOW VOLTAGE DIRECTIVE)

We SSD Drives Limited, address as below, declare under our sole responsibility that the above Electronic Products when installed and operated with reference to the instructions in the Product Manual (provided with each piece of equipment), is in accordance with the following standard :-

EN50178 (1998)

Issued for compliance with the EMC Directive when the unit is used as *relevant apparatus*.

The drive is CE marked in accordance with the low voltage directive for electrical equipment and appliances in the voltage range when installed correctly.

MANUFACTURERS DECLARATIONS

EMC Declaration

We SSD Drives Limited, address as below, declare under our sole responsibility that the above Electronic Products when installed and operated with reference to the instructions in the Product Manual (provided with each piece of equipment) is in accordance with the relevant clauses from the following standard:-

BSEN61800-3 (1997)

Machinery Directive

The above Electronic Products are components to be incorporated into machinery and may not be operated alone.

The complete machinery or installation using this equipment may only be put into service when the safety considerations of the Directive 89/392/EEC are fully adhered to.

Particular reference should be made to EN60204-1 (Safety of Machinery - Electrical Equipment of Machines).

All instructions, warnings and safety information of the Product Manual must be adhered to.

This is provided to aid your justification for EMC compliance when the unit is used as a component.

Since the potential hazards are mainly electrical rather than mechanical, the drive does not fall under the machinery directive. However, we do supply a manufacturer's declaration for when the drive is used (as a component) in machinery.

Dr Martin Payn (Conformance Officer)

SSD DRIVES LIMITED

NEW COURTWICK LANE, LITTLEHAMPTON, WEST SUSSEX BN17 7RZ

TELEPHONE: +44(0)1903 737000 FAX: +44(0)1903 737100

Registered Number: 1159876 England. Registered Office: New Courtwick Lane, Littlehampton, West Sussex BN17 5PU

File Name: C:\Documents and Settings\jrich\My Documents\Temp docs\hp467607.919

© 2005 SSD DRIVES LIMITED

ISS:	DATE	DRN: J.Mc	CHKD: MP	DRAWING NUMBER: HK467607.919	
A	20/01/01			TITLE:	SHT 4
				Declarations of Conformity	OF
					1 SHTS

650V 0.37 -7.5kW 400V



EC DECLARATIONS OF CONFORMITY

Date CE marked first applied: 26/07/2001

EMC Directive

In accordance with the EEC Directive 89/336/EEC and amended by 92/31/EEC and 93/68/EEC, Article 10 and Annex I, (EMC DIRECTIVE)

We Eurotherm Drives Limited, address as below, declare under our sole responsibility that the above Electronic Products when installed and operated with reference to the instructions in the Product Manual (provided with each piece of equipment) is in accordance with the relevant clauses from the following standard:-

BSEN61800-3 (1997)

Low Voltage Directive

In accordance with the EEC Directive 73/23/EEC and amended by 93/68/EEC, Article 13 and Annex III, (LOW VOLTAGE DIRECTIVE)

We Eurotherm Drives Limited, address as below, declare under our sole responsibility that the above Electronic Products when installed and operated with reference to the instructions in the Product Manual (provided with each piece of equipment), is in accordance with the following standard :-

EN50178 (1998)

Issued for compliance with the EMC Directive when the unit is used as *relevant apparatus*.

The drive is CE marked in accordance with the low voltage directive for electrical equipment and appliances in the voltage range when installed correctly.

MANUFACTURERS DECLARATIONS

EMC Declaration

We Eurotherm Drives Limited, address as below, declare under our sole responsibility that the above Electronic Products when installed and operated with reference to the instructions in the Product Manual (provided with each piece of equipment) is in accordance with the relevant clauses from the following standard:-

BSEN61800-3 (1997)

Machinery Directive

The above Electronic Products are components to be incorporated into machinery and may not be operated alone.

The complete machinery or installation using this equipment may only be put into service when the safety considerations of the Directive 89/392/EEC are fully adhered to.

Particular reference should be made to EN60204-1 (Safety of Machinery - Electrical Equipment of Machines).

All instructions, warnings and safety information of the Product Manual must be adhered to.

This is provided to aid your justification for EMC compliance when the unit is used as a component.

Since the potential hazards are mainly electrical rather than mechanical, the drive does not fall under the machinery directive. However, we do supply a manufacturer's declaration for when the drive is used(as a component) in machinery.

Dr Martin Payn (Conformance Officer)

EUROTHERM DRIVES LIMITED

NEW COURTWICK LANE, LITTLEHAMPTON, WEST SUSSEX BN17 7RZ
TELEPHONE: +44(0)1903 737000 FAX: +44(0)1903 737100

Registered Number: 1159876 England. Registered Office: New Courtwick Lane, Littlehampton, West Sussex BN17 5PU

File Name: C:\Documents and Settings\jrich\My Documents\Temp docs\hp467607.919 © 1999 EUROTHERM DRIVES LIMITED

ISS:	DATE	DRN: J.Mc	CHKD: MP	DRAWING NUMBER: HK467607.919	
A	20/01/01			TITLE:	SHT 5
				Declarations of Conformity	OF
					1 SHTS

SERIAL COMMUNICATIONS

Connection to the P3 Port

IMPORTANT: The drive **MUST be earthed**. Failure to do so could damage your communications ports.

The port is an un-isolated RS232, 19200 Baud, supporting the standard EI bisynch ASCII communications protocol. Contact SSD Drives for further information.

The P3 port is located under the terminal cover and is used only by the remote-mounted RS232 Keypad.

P3 Port

A standard P3 lead is used to connect to the drive.

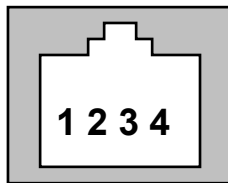

P3 Port Pin	Lead	Signal
1	Black	0V
2	Red	5V
3	Green	TX
4	Yellow	RX

Note: There is 5V present on pin 2 of the P3 port - do not connect this to your PC.

APPLICATIONS

The Default Application

The drive is supplied with 6 Applications, Application 0 to Application 5. Each Application recalls a pre-programmed structure of internal links when it is loaded.

DEFAULT

- Application 0 will not control a motor. Loading Application 0 removes all internal links.
- Application 1 is the factory default application, providing for basic speed control
- Application 2 supplies speed control using a manual or auto setpoint
- Application 3 supplies speed control using preset speeds
- Application 4 is a set-up providing speed control with Raise/Lower Trim
- Application 5 supplies speed control with Run Forward/Run Reverse

IMPORTANT: Refer to Chapter 5: The Keypad – Special Menu Features to reset the drive to factory default values which are suitable for most applications.

How to Load an Application

In the **PRG** menu, go to **P I** and press the **M** key twice.

The Applications are stored in this menu.

Use the **▲** **▼** keys to select the appropriate Application by number.

Press the **E** key to load the Application.

Application Description

Control Wiring for Applications

The large Application Diagrams on the following pages show the full wiring for push-button starting. The diagrams on the reverse show the full wiring for single wire starting.

For the minimum connections to make the drive run refer to Chapter 3: "Installing the Drive" - Electrical Installation; the remaining connections can be made to suit your system.

When you load an Application, the input and output parameters shown in these diagrams default to the settings shown. For alternative user-settings refer to the Software Product Manual, Chapter 1 "Programming Your Application".

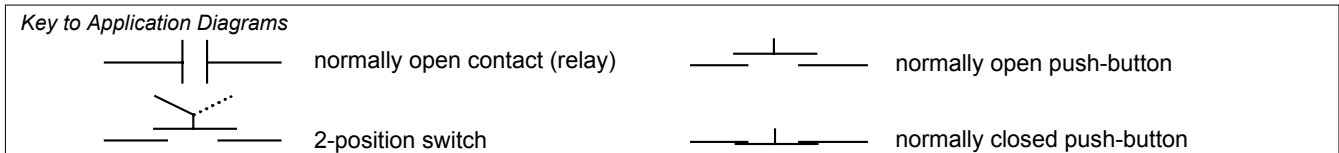

Application 1 : Basic Speed Control (default)

- STANDARD PARAMETERS**
- p1 Application
 - p2 Max speed
 - p3 Min speed
 - p4 Accel time
 - p5 Decel time
 - p6 Motor rated current
 - p7 Base frequency
 - p8 Jog setpoint
 - p9 Stop mode
 - p11 V/F shape
 - p12 HVAC ratings
 - p13 Fixed boost, (VF only)
 - p99 Password

- DIAGNOSTICS**
- Frequency Hz
 - Speed Setpt %
 - DC Link Volts V
 - Motor Current A

Application 1: Basic Speed Control

IDEAL FOR GENERAL PURPOSE APPLICATIONS,
CONSTANT TORQUE AND VARIABLE TORQUE

P1 APPLICATION = 1

Italic text indicates Default

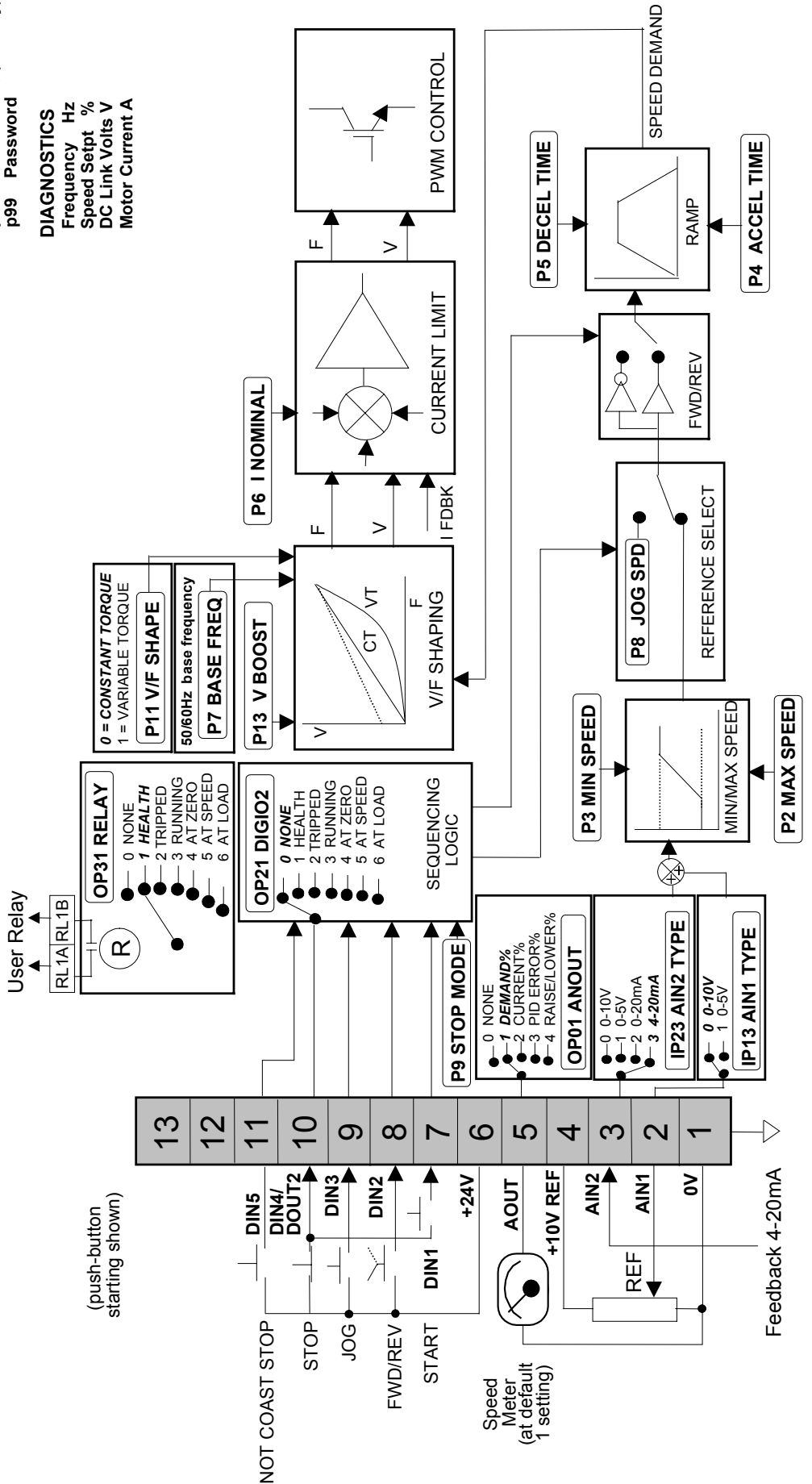
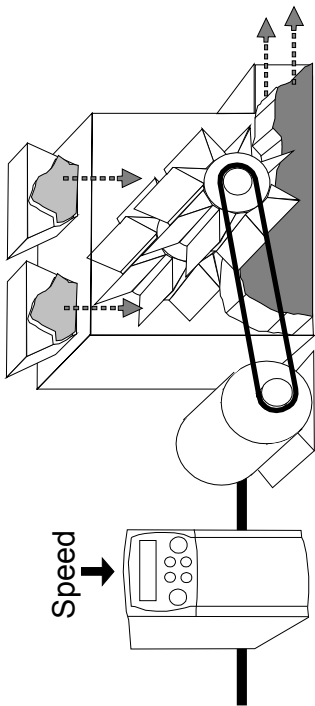

Application 1: Basic Speed Control (default)

This Application is ideal for general purpose applications. It provides push-button or switched start/stop control. The setpoint is the sum of the two analogue inputs AIN1 and AIN2, providing Speed Setpoint + Speed Trim capability.

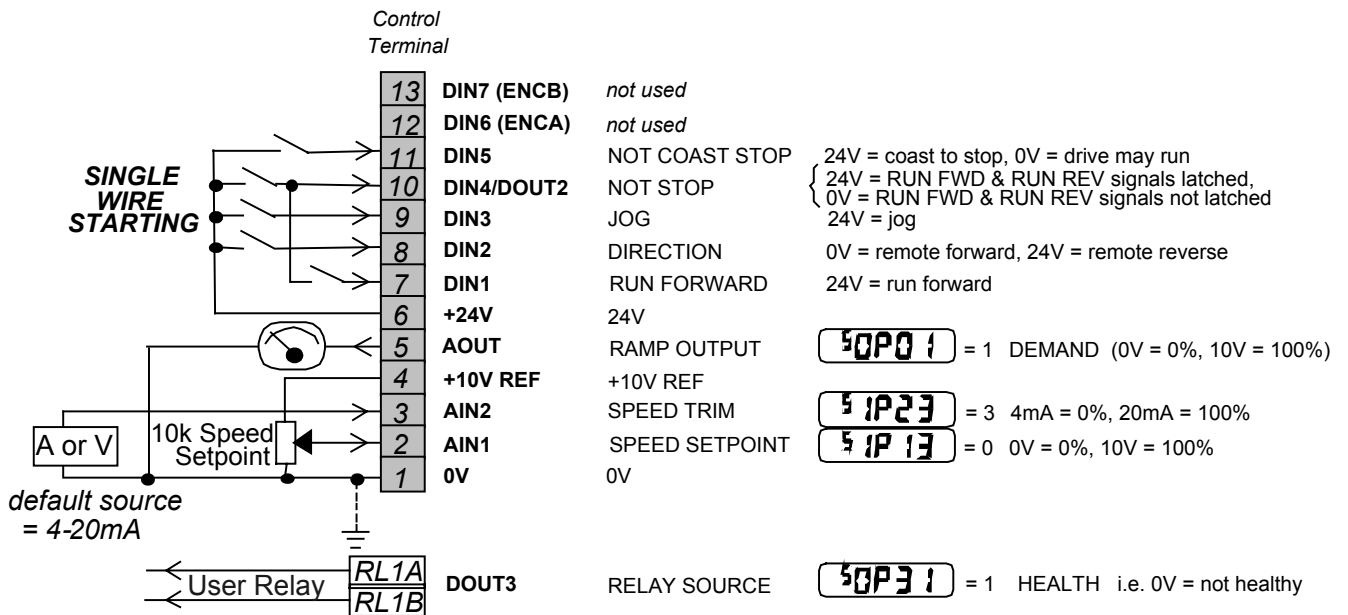

Application 2 : Auto/Manual Control

- STANDARD PARAMETERS**
- p1 Application
 - p2 Max speed
 - p3 Min speed
 - p4 Accel time
 - p5 Decel time
 - p6 Motor rated current
 - p7 Base frequency
 - p8 Jog setpoint
 - p9 Stop mode
 - p11 V/F shape
 - p12 HVAC ratings
 - p13 Fixed boost, (VF only)
 - p99 Password

- DIAGNOSTICS**
- Frequency Hz
 - Speed Setpt %
 - DC Link Volts V
 - Motor Current A

Application 2: Auto/Manual Control

IDEAL FOR AUTOMATIC CONTROL APPLICATIONS
WITH LIMIT SWITCHES OR PROXIMITY TRANSDUCERS

P1 APPLICATION = 2

Italic text indicates Default

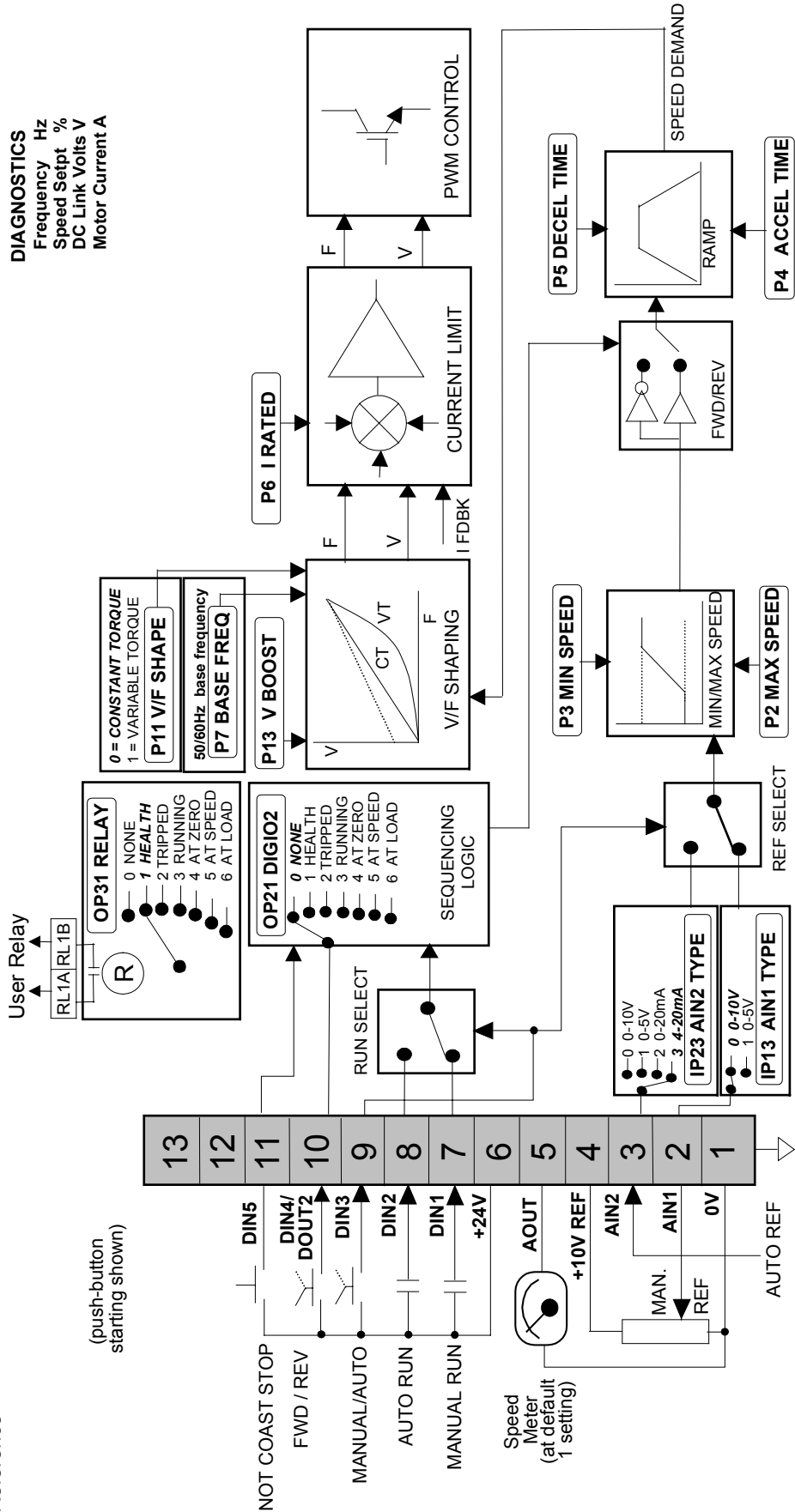
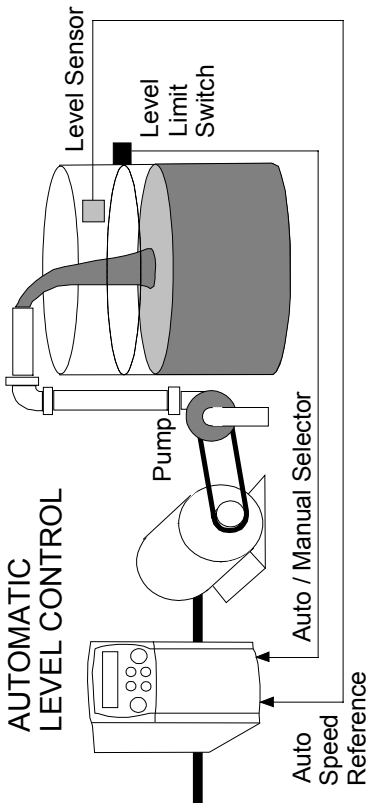

Application 2: Auto/Manual Control

Two Run inputs and two Setpoint inputs are provided. The Auto/Manual switch selects which pair of inputs is active. The Application is sometimes referred to as Local/Remote.

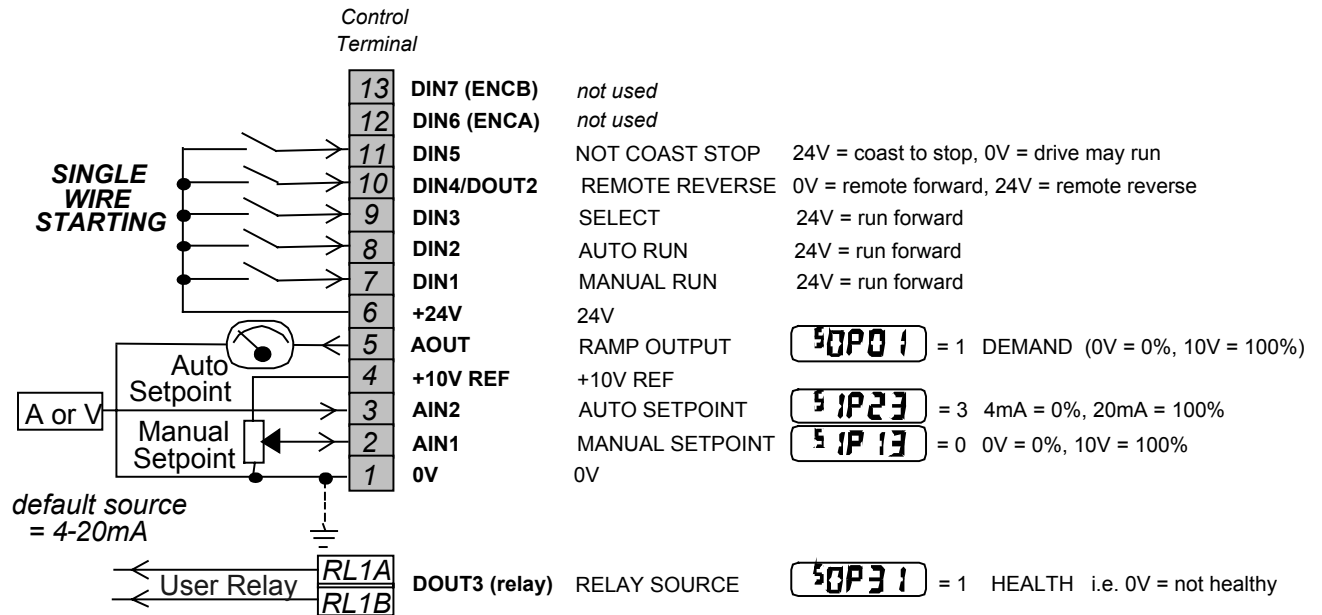

Application 3 : Preset Speeds

STANDARD PARAMETERS

- p1 Application
- p2 Max speed
- p3 Min speed
- p4 Accel time
- p5 Decel time
- p6 Motor rated current
- p7 Base frequency
- p8 Jog setpoint
- p9 Stop mode
- p11 V/F shape
- p12 HVAC ratings
- p13 Fixed boost, (VF only)
- p99 Password

DIAGNOSTICS

- Frequency Hz
- Speed Setpt %
- DC Link Volts V
- Motor Current A

Application 3: Preset Speeds

IDEAL FOR APPLICATIONS REQUIRING
MULTIPLE DISCRETE SPEED LEVELS

P1 APPLICATION = 3

Italic text indicates Default

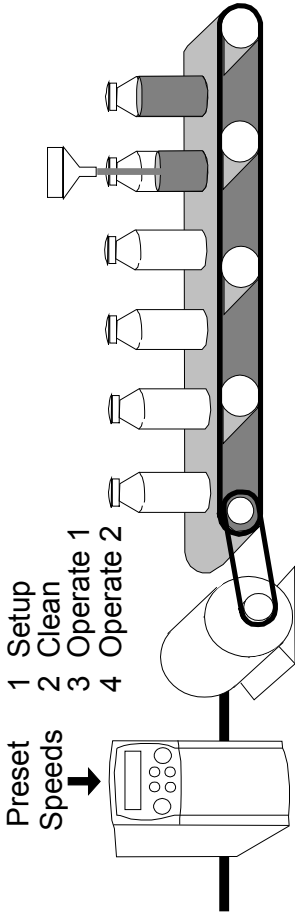

- 1 Setup
- 2 Clean
- 3 Operate 1
- 4 Operate 2

- 0 = CONSTANT TORQUE
- 1 = VARIABLE TORQUE
- P11 V/F SHAPE**
- 50/60Hz base frequency
- P7 BASE FREQ**

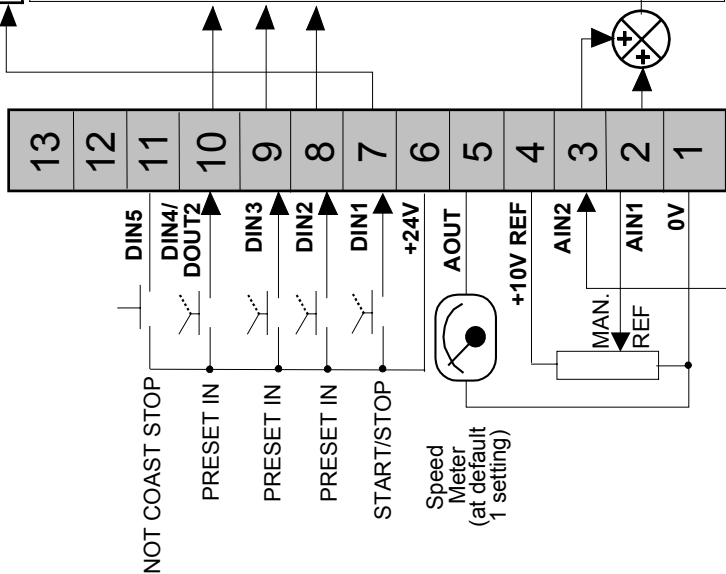
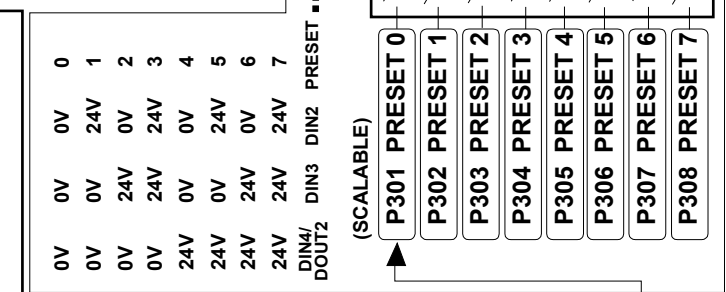
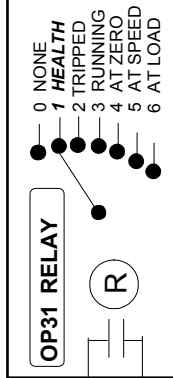

Application 3: Preset Speeds

This is ideal for applications requiring multiple discrete speed levels.

The setpoint is selected from either the sum of the analogue inputs, (as in Application 1 and known here as PRESET 0), or as one of up to seven other pre-defined speed levels. These are selected using DIN2, DIN3 and DIN4, refer to the Truth Table below.

Edit parameters P_{302} to P_{308} on the keypad to re-define the speed levels of PRESET 1 to PRESET 7. Reverse direction is achieved by entering a negative speed setpoint.

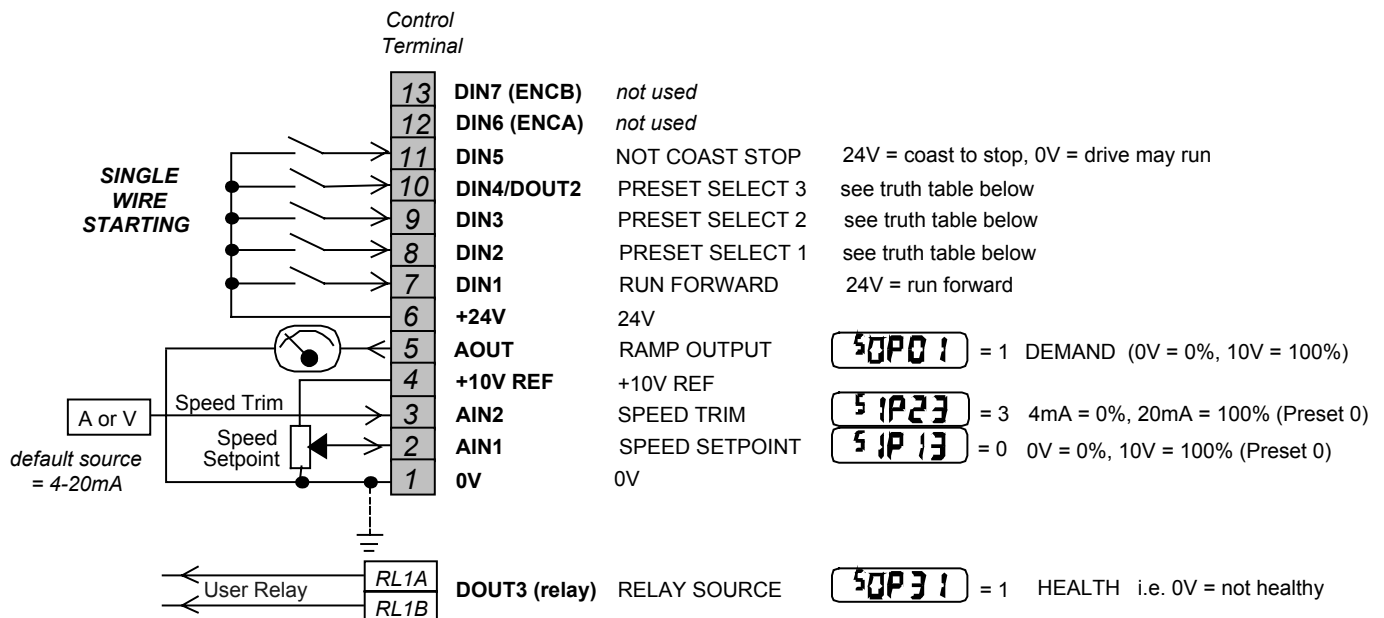

Preset Speed Truth Table

DIN4/DOUT2	DIN3	DIN2	Preset
0V	0V	0V	0
0V	0V	24V	1
0V	24V	0V	2
0V	24V	24V	3
24V	0V	0V	4
24V	0V	24V	5
24V	24V	0V	6
24V	24V	24V	7

Application 4 : Raise/Lower Trim

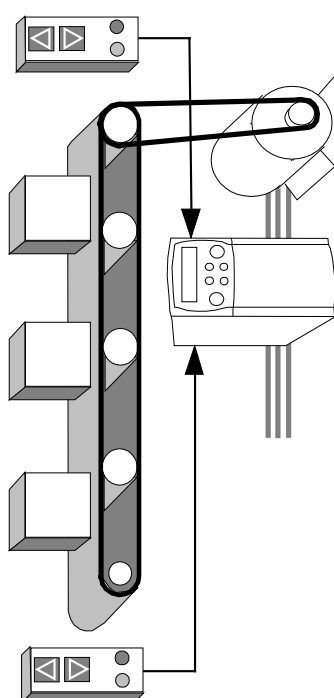

Application 4: Raise/Lower

IDEAL FOR APPLICATIONS REQUIRING
SPEED CONTROL FROM MULTIPLE LOCATIONS

P1 APPLICATION = 4

Italic text indicates Default

STANDARD PARAMETERS

- p1 Application
- p2 Max speed
- p3 Min speed
- p4 Accel time
- p5 Decel time
- p6 Motor rated current
- p7 Base frequency
- p8 Jog setpoint
- p9 Stop mode
- p11 V/F shape
- p12 HVAC ratings
- p13 Fixed boost, (VF only)
- p99 Password

DIAGNOSTICS

- Frequency Hz
- Speed Setpt %
- DC Link Volts V
- Motor Current A

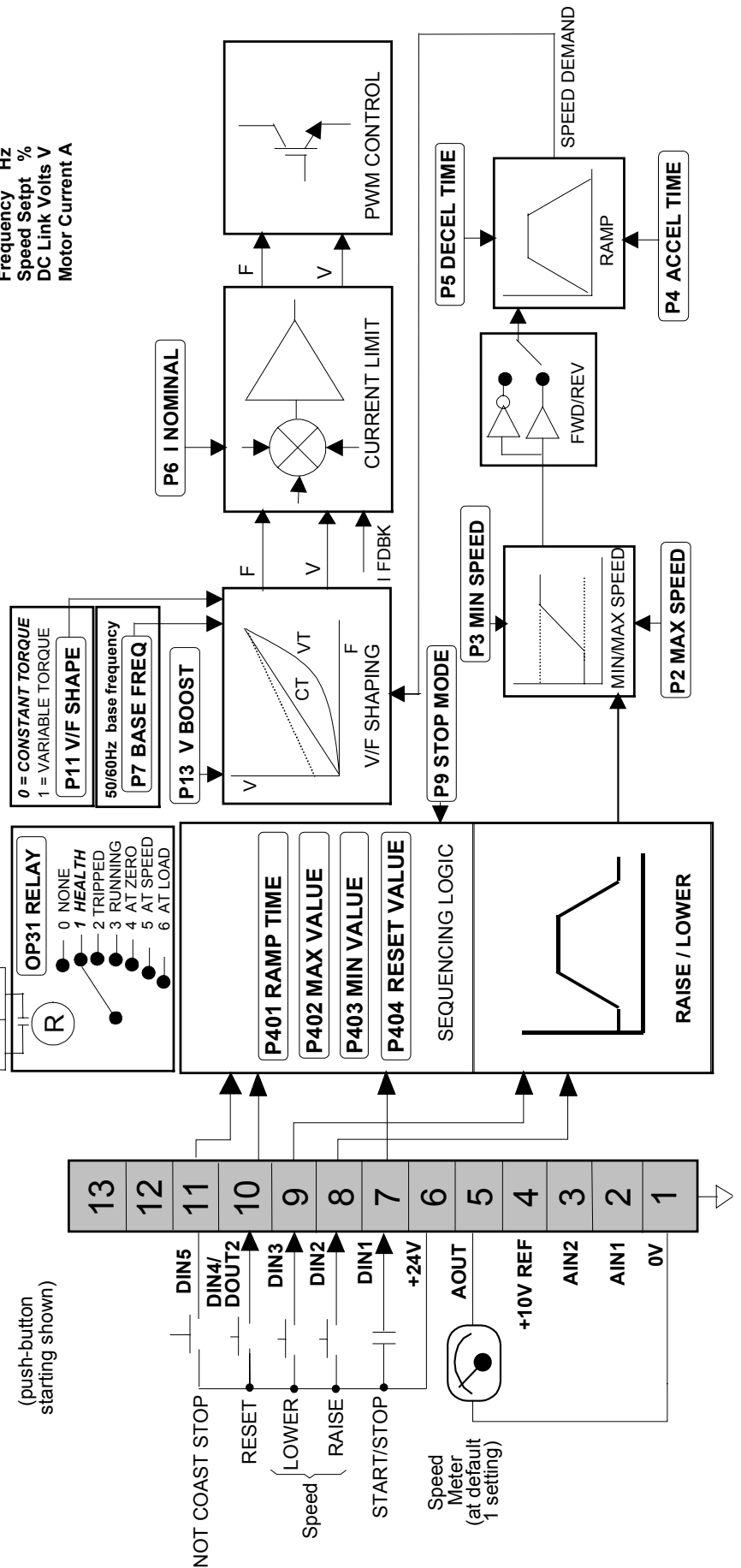

Application 4: Raise/Lower Trim

This Application mimics the operation of a motorised potentiometer. Digital inputs allow the setpoint to be increased and decreased between limits. The limits and ramp rate can be set using the keypad.

The Application is sometimes referred to as Motorised Potentiometer.

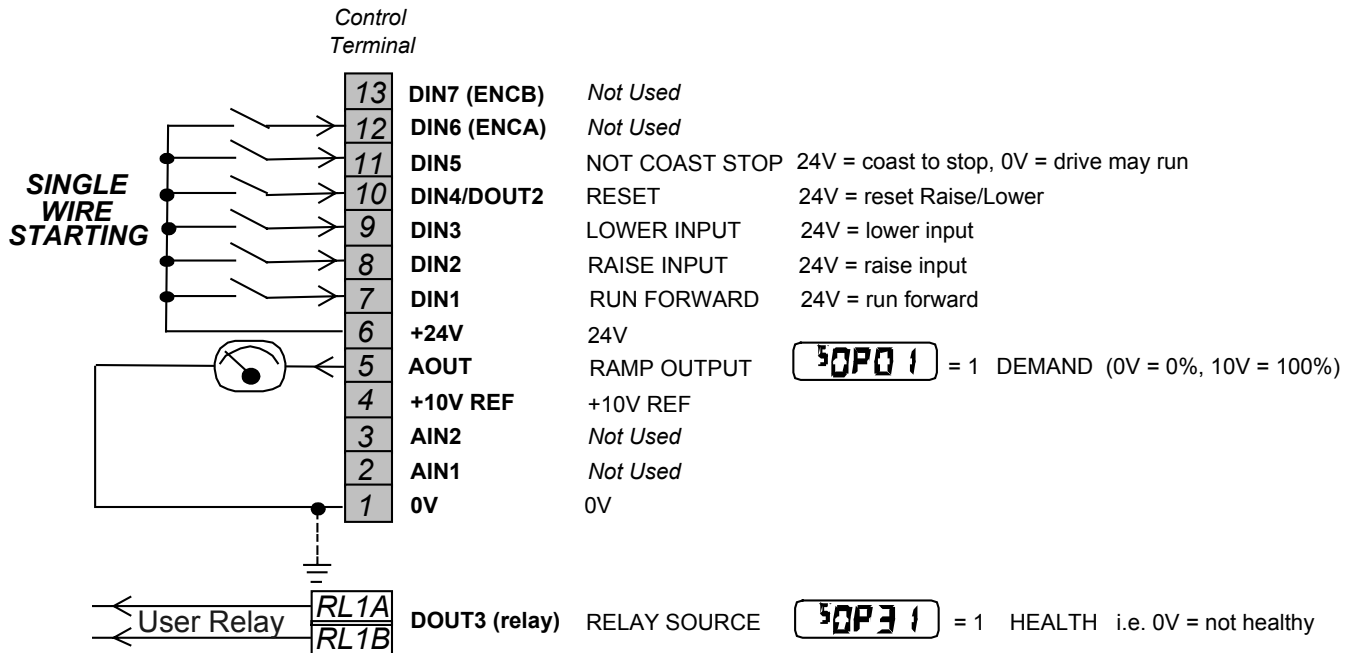

Application 5 : PID

Application 5: PI Control

EASY TUNING FOR SETPOINT/FEEDBACK CONTROL
APPLICATIONS REGULATING VOLUME OR PRESSURE
SUCH AS AIR HANDLING OR PUMPING

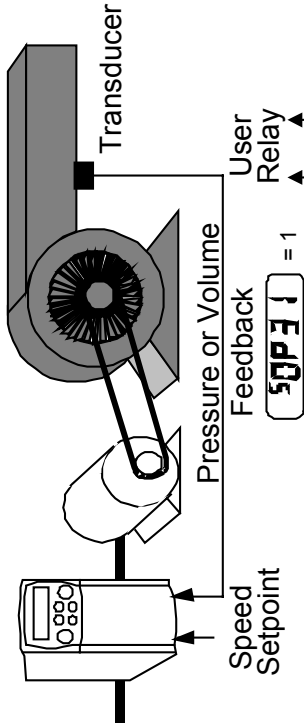

- STANDARD PARAMETERS**
- p1 Application
 - p2 Max speed
 - p3 Min speed
 - p4 Accel time
 - p5 Decel time
 - p6 Motor current
 - p7 Base frequency
 - p8 Jog setpoint
 - p9 Run stop mode
 - p11 V/F shape
 - p12 Normal duty
 - p13 Fixed boost, (VF only)
 - p99 Password

P1 = 5

Italic text indicates Default

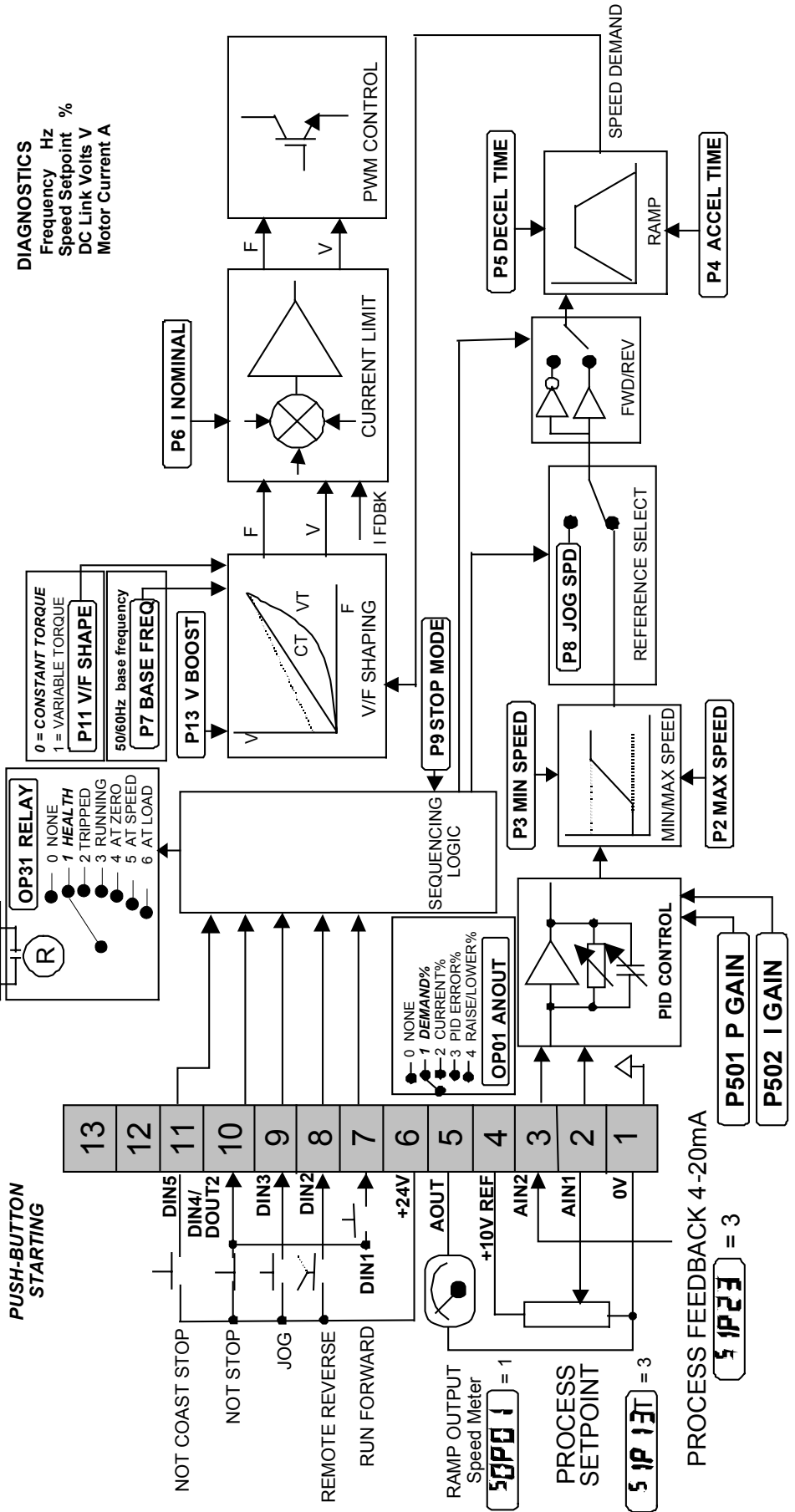

Application 5: PID

A simple application using a Proportional-Integral-Derivative 3-term controller. The setpoint is taken from AIN1, with feedback signal from the process on AIN2. The scale and offset features of the analogue input blocks may be used to correctly scale these signals. The difference between these two signals is taken as the PID error. The output of the PID block is then used as the drive setpoint.

